

Challenge V and Wedge Belts

Classical 'V' Belts ISO 4184, BS 3790, DIN 2215, RMA IP20

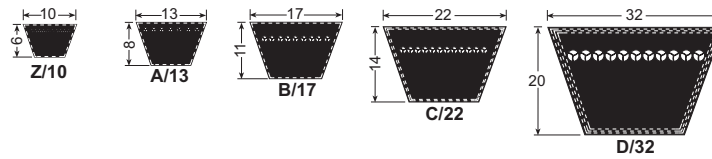

Section	Z	A	B	C	D
Top Width	10.0	13.0	17.0	22.0	32.0
Pitch Width	8.5	11.0	14.0	19.0	27.0
Section Height	6.0	8.0	11.0	14.0	19.0
Inside Length <small>Li = Lp minus α</small>	$\alpha = 22$	$\alpha = 30$	$\alpha = 40$	$\alpha = 58$	$\alpha = 75$
Outside Length <small>La = Li plus y</small>	$y = 38$	$y = 50$	$y = 69$	$y = 88$	$y = 126$

Wedge Belts ISO 4184, BS 3790, DIN 7753, RMA IP22

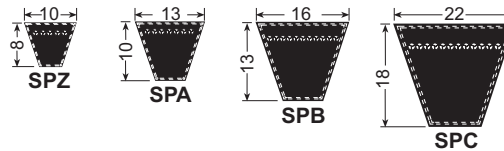

Section	SPZ	SPA	SPB	SPC
Top Width	10.0	13.0	16.0	22.0
Pitch Width	8.5	11.0	14.0	19.0
Section Height	8.0	10.0	13.0	18.0
Inside Length <small>Li = Lp minus α</small>	$\alpha = 37$	$\alpha = 45$	$\alpha = 60$	$\alpha = 83$
Outside Length <small>La = Li plus y</small>	$y = 50$	$y = 63$	$y = 82$	$y = 113$

Narrow V Belts RMA IP22

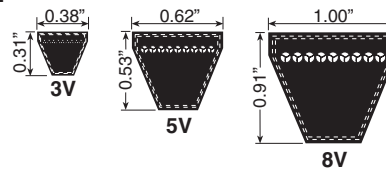

Section	3V	5V	8V
Top Width <small>Nominal inch</small>	0.38	0.62	1.00
Section Height <small>Nominal inch</small>	0.31	0.53	0.91
Inside Length <small>Li = Lp minus α inch</small>	$\alpha = 1.95$	$\alpha = 3.33$	$\alpha = 3.90$

Belt Mass

Section - V kg/m	Z	A	B	C	D
	0.060	0.100	0.175	0.305	0.635
Section - Wedge kg/m	SPZ	SPA	SPB	SPC	
	0.072	0.115	0.190	0.360	
Section - Wedge lbs/foot	3V	5V	8V		
	0.055	0.156	0.420		

Lp = Pitch Length
Li = Inside Length
La = Outside Length

Challenge belts have excellent heat and oil resistance as well as anti static properties and conform to ISO1813. The Challenge belt factory has ISO 9001 certification.

Working Temperature:

-30°C to +70°C

Classical V-Belts

Z 10 x 6						A 13 x 8					
Imperial Li	Metric Lp	Metric Li	Imperial Li	Metric Lp	Metric Li	Imperial Li	Metric Lp	Metric Li	Imperial Li	Metric Lp	Metric Li
Z15	10 x 410	385	Z46.5	10 x 1210	1185	A18	13 x 490	460	A74	13 x 1920	1890
Z15.5	10 x 420	395	Z47	10 x 1220	1195	A19	13 x 520	490	A75	13 x 1940	1910
Z15.7	10 x 425	400	Z48	10 x 1240	1215	A20	13 x 540	510	A76	13 x 1960	1930
Z16.5	10 x 445	420	Z49	10 x 1270	1245	A21	13 x 570	540	A77	13 x 1990	1960
Z16.7	10 x 450	425	Z50	10 x 1290	1265	A22	13 x 590	560	A78	13 x 2020	1990
Z17.5	10 x 470	445	Z51	10 x 1320	1295	A23	13 x 620	590	A79	13 x 2050	2020
Z17.7	10 x 475	450	Z52	10 x 1340	1315	A24	13 x 650	620	A80	13 x 2070	2040
Z18	10 x 480	455	Z53	10 x 1370	1345	A25	13 x 670	640	A81	13 x 2090	2060
Z18.5	10 x 495	470	Z54	10 x 1390	1365	A26	13 x 700	670	A82	13 x 2120	2090
Z19	10 x 510	485	Z55	10 x 1420	1395	A27	13 x 720	690	A83	13 x 2140	2110
Z19.5	10 x 520	495	Z56	10 x 1450	1425	A28	13 x 750	720	A84	13 x 2170	2140
Z20	10 x 530	505	Z57	10 x 1470	1445	A29	13 x 770	740	A85	13 x 2190	2160
Z20.5	10 x 545	520	Z58	10 x 1500	1475	A30	13 x 800	770	A86	13 x 2220	2190
Z21	10 x 560	535	Z59	10 x 1520	1495	A31	13 x 820	790	A87	13 x 2240	2210
Z21.7	10 x 575	550	Z60	10 x 1550	1525	A32	13 x 850	820	A88	13 x 2270	2240
Z22	10 x 580	555	Z62	10 x 1600	1575	A33	13 x 870	840	A89	13 x 2300	2270
Z22.2	10 x 585	560	Z63	10 x 1620	1595	A34	13 x 900	870	A90	13 x 2320	2290
Z23	10 x 610	585	Z64	10 x 1650	1625	A35	13 x 920	890	A91	13 x 2350	2320
Z23.5	10 x 620	595	Z68	10 x 1750	1725	A36	13 x 950	920	A92	13 x 2370	2340
Z24	10 x 630	605	Z75	10 x 1920	1895	A37	13 x 980	950	A93	13 x 2400	2370
Z24.7	10 x 655	630	Z78	10 x 2000	1975	A38	13 x 1000	970	A94	13 x 2420	2390
Z25	10 x 660	635				A39	13 x 1030	1000	A95	13 x 2450	2420
Z25.7	10 x 675	655				A40	13 x 1050	1020	A96	13 x 2470	2440
Z26	10 x 680	660				A41	13 x 1080	1050	A97	13 x 2500	2470
Z26.5	10 x 700	675				A42	13 x 1100	1070	A98	13 x 2530	2500
Z27	10 x 710	685				A43	13 x 1130	1100	A99	13 x 2550	2520
Z28	10 x 730	705				A44	13 x 1150	1120	A100	13 x 2580	2550
Z29	10 x 760	735				A45	13 x 1180	1150	A102	13 x 2630	2600
Z29.5	10 x 770	745				A46	13 x 1200	1170	A103	13 x 2650	2620
Z30	10 x 780	755				A47	13 x 1230	1200	A104	13 x 2680	2650
Z30.7	10 x 805	780				A48	13 x 1250	1220	A105	13 x 2700	2670
Z31	10 x 810	785				A49	13 x 1280	1250	A106	13 x 2730	2700
Z31.5	10 x 820	795				A50	13 x 1310	1280	A107	13 x 2750	2720
Z32	10 x 840	815				A51	13 x 1330	1300	A108	13 x 2780	2750
Z33	10 x 860	835				A52	13 x 1360	1330	A109	13 x 2800	2770
Z33.7	10 x 880	855				A53	13 x 1380	1350	A110	13 x 2830	2800
Z34	10 x 890	865				A54	13 x 1410	1380	A112	13 x 2880	2850
Z35	10 x 910	885				A55	13 x 1430	1400	A113	13 x 2910	2880
Z35.5	10 x 930	905				A56	13 x 1460	1430	A115	13 x 2960	2930
Z36	10 x 940	915				A57	13 x 1480	1450	A116	13 x 2980	2950
Z36.5	10 x 950	925				A58	13 x 1510	1480	A117	13 x 3010	2980
Z37	10 x 960	935				A59	13 x 1530	1500	A118	13 x 3030	3000
Z37.5	10 x 980	945				A60	13 x 1560	1530	A120	13 x 3080	3050
Z38	10 x 990	955				A61	13 x 1580	1550	A124	13 x 3190	3160
Z39	10 x 1010	985				A62	13 x 1610	1580	A125	13 x 3200	3170
Z39.5	10 x 1030	1005				A63	13 x 1640	1610	A128	13 x 3290	3260
Z40	10 x 1040	1015				A64	13 x 1660	1630	A130	13 x 3340	3310
Z40.5	10 x 1050	1025				A65	13 x 1690	1660	A132	13 x 3390	3360
Z41	10 x 1060	1035				A66	13 x 1710	1680	A134	13 x 3440	3410
Z42	10 x 1090	1065				A67	13 x 1740	1710	A136	13 x 3490	3460
Z42.5	10 x 1100	1075				A68	13 x 1760	1730	A138	13 x 3540	3510
Z43	10 x 1120	1095				A69	13 x 1790	1760	A140	13 x 3590	3560
Z44	10 x 1140	1115				A70	13 x 1810	1780	A144	13 x 3690	3660
Z45	10 x 1170	1145				A71	13 x 1840	1810	A154	13 x 3950	3920
Z45.5	10 x 1180	1155				A72	13 x 1860	1830	A158	13 x 4050	4020
Z46	10 x 1190	1165				A73	13 x 1890	1860	A173	13 x 4430	4400

Classical V-Belts

B 17 x 11								
Imperial Li	Metric Lp	Metric Li	Imperial Li	Metric Lp	Metric Li	Imperial Li	Metric Lp	Metric Li
B22	17 x 600	560	B79	17 x 2050	2010	B148	17 x 3800	3760
B24	17 x 650	610	B80	17 x 2080	2040	B150	17 x 3850	3810
B25	17 x 670	630	B81	17 x 2100	2060	B152	17 x 3900	3860
B26	17 x 700	660	B82	17 x 2130	2090	B154	17 x 3950	3910
B28	17 x 750	710	B83	17 x 2150	2110	B155	17 x 3980	3940
B29	17 x 780	740	B84	17 x 2180	2140	B158	17 x 4060	4020
B30	17 x 810	770	B85	17 x 2200	2160	B160	17 x 4110	4050
B31	17 x 830	790	B86	17 x 2230	2190	B162	17 x 4160	4120
B32	17 x 860	820	B87	17 x 2250	2210	B164	17 x 4210	4170
B33	17 x 880	840	B88	17 x 2280	2240	B166	17 x 4260	4220
B34	17 x 910	870	B89	17 x 2300	2260	B168	17 x 4310	4270
B35	17 x 930	890	B90	17 x 2330	2290	B173	17 x 4440	4400
B36	17 x 960	920	B91	17 x 2350	2310	B180	17 x 4620	4580
B37	17 x 980	940	B92	17 x 2380	2340	B184	17 x 4720	4670
B38	17 x 1010	970	B93	17 x 2410	2370	B185	17 x 4740	4700
B39	17 x 1030	990	B94	17 x 2420	2380	B187	17 x 4790	4750
B40	17 x 1060	1020	B95	17 x 2460	2420	B193	17 x 4940	4900
B41	17 x 1080	1040	B96	17 x 2480	2440	B194	17 x 4970	4930
B42	17 x 1110	1070	B97	17 x 2510	2470	B195	17 x 5000	4960
B43	17 x 1130	1090	B98	17 x 2530	2490	B197	17 x 5050	5010
B44	17 x 1160	1120	B99	17 x 2560	2520	B204	17 x 5220	5180
B45	17 x 1180	1140	B100	17 x 2580	2540	B210	17 x 5380	5340
B46	17 x 1210	1170	B101	17 x 2610	2570	B215	17 x 5510	5470
B47	17 x 1240	1200	B102	17 x 2630	2590	B220	17 x 5630	5590
B48	17 x 1260	1220	B103	17 x 2660	2620	B222	17 x 5680	5640
B49	17 x 1290	1250	B104	17 x 2680	2640	B225	17 x 5760	5720
B50	17 x 1310	1270	B105	17 x 2710	2670	B238	17 x 6090	6050
B51	17 x 1340	1300	B106	17 x 2740	2700	B240	17 x 6120	6080
B52	17 x 1370	1330	B107	17 x 2760	2720	B255	17 x 6500	6460
B53	17 x 1390	1350	B108	17 x 2790	2750	B256	17 x 6550	6490
B54	17 x 1410	1370	B110	17 x 2840	2800	B264	17 x 6750	6710
B55	17 x 1440	1400	B111	17 x 2870	2830	B268	17 x 6850	6810
B56	17 x 1470	1430	B112	17 x 2890	2850	B298	17 x 7610	7570
B57	17 x 1490	1450	B113	17 x 2920	2880	B358	17 x 9140	9100
B58	17 x 1520	1480	B114	17 x 2940	2900			
B59	17 x 1540	1500	B115	17 x 2960	2920			
B60	17 x 1570	1530	B116	17 x 2990	2950			
B61	17 x 1590	1550	B117	17 x 3020	2980			
B62	17 x 1620	1580	B118	17 x 3040	3000			
B63	17 x 1640	1600	B120	17 x 3090	3050			
B64	17 x 1670	1630	B122	17 x 3140	3100			
B65	17 x 1690	1650	B124	17 x 3190	3150			
B66	17 x 1720	1680	B125	17 x 3220	3160			
B66.5	17 x 1730	1690	B126	17 x 3240	3200			
B67	17 x 1740	1700	B128	17 x 3290	3250			
B68	17 x 1770	1730	B130	17 x 3350	3310			
B69	17 x 1800	1760	B131	17 x 3380	3340			
B70	17 x 1820	1780	B132	17 x 3400	3360			
B71	17 x 1850	1810	B134	17 x 3450	3410			
B72	17 x 1870	1830	B135	17 x 3480	3440			
B73	17 x 1900	1860	B136	17 x 3500	3460			
B74	17 x 1920	1880	B138	17 x 3550	3510			
B75	17 x 1950	1910	B140	17 x 3600	3560			
B76	17 x 1970	1930	B142	17 x 3650	3610			
B77	17 x 2000	1960	B144	17 x 3700	3660			
B78	17 x 2020	1980	B146	17 x 3750	3710			

All dimensions in millimetres unless otherwise stated. Every effort has been taken to ensure that the data listed in this catalogue is correct. Challenge accepts no liability for any inaccuracies or damage caused.

Classical V-Belts

C 22 x 14

Imperial Li	Metric Lp	Metric Li	Imperial Li	Metric Lp	Metric Li	Imperial Li	Metric Lp	Metric Li
C40	22 x 1070	1012	C111	22 x 2880	2822	C268	22 x 6860	6802
C42	22 x 1120	1062	C112	22 x 2900	2842	C270	22 x 6910	6852
C43	22 x 1150	1092	C114	22 x 2950	2892	C285	22 x 7290	7232
C44	22 x 1170	1112	C115	22 x 2980	2922	C298	22 x 7630	7572
C45	22 x 1200	1142	C116	22 x 3000	2942	C300	22 x 7670	7612
C46	22 x 1220	1162	C118	22 x 3050	2992	C314	22 x 8030	7972
C48	22 x 1270	1212	C119	22 x 3080	3022	C330	22 x 8440	8382
C50	22 x 1320	1262	C120	22 x 3100	3042	C345	22 x 8820	8762
C51	22 x 1350	1292	C122	22 x 3160	3102	C360	22 x 9200	9142
C52	22 x 1380	1322	C123	22 x 3190	3132	C420	22 x 10690	10632
C53	22 x 1400	1342	C124	22 x 3210	3152			
C54	22 x 1430	1372	C125	22 x 3240	3182			
C55	22 x 1450	1392	C128	22 x 3310	3252			
C56	22 x 1480	1422	C130	22 x 3360	3302			
C57	22 x 1510	1452	C131	22 x 3390	3332			
C58	22 x 1530	1472	C132	22 x 3410	3352			
C59	22 x 1560	1502	C133	22 x 3430	3372			
C60	22 x 1580	1522	C134	22 x 3460	3402			
C61	22 x 1610	1552	C136	22 x 3510	3452			
C62	22 x 1630	1572	C138	22 x 3560	3502			
C63	22 x 1660	1602	C140	22 x 3610	3552			
C64	22 x 1680	1622	C141	22 x 3640	3582			
C65	22 x 1700	1642	C142	22 x 3660	3602			
C67	22 x 1760	1702	C143	22 x 3690	3632			
C68	22 x 1780	1722	C144	22 x 3710	3652			
C69	22 x 1810	1752	C145	22 x 3740	3682			
C70	22 x 1830	1772	C146	22 x 3760	3702			
C71	22 x 1860	1802	C148	22 x 3820	3762			
C72	22 x 1880	1822	C150	22 x 3870	3812			
C73	22 x 1910	1852	C152	22 x 3920	3862			
C74	22 x 1930	1872	C154	22 x 3970	3912			
C75	22 x 1960	1902	C156	22 x 4020	3962			
C76	22 x 1980	1922	C158	22 x 4070	4012			
C77	22 x 2010	1952	C159	22 x 4100	4042			
C78	22 x 2040	1982	C160	22 x 4120	4062			
C79	22 x 2060	2002	C162	22 x 4170	4112			
C80	22 x 2090	2032	C164	22 x 4220	4162			
C81	22 x 2110	2052	C166	22 x 4270	4212			
C82	22 x 2140	2082	C167	22 x 4300	4242			
C83	22 x 2160	2102	C168	22 x 4320	4262			
C84	22 x 2190	2132	C170	22 x 4370	4312			
C85	22 x 2210	2152	C173	22 x 4450	4392			
C86	22 x 2230	2172	C175	22 x 4500	4442			
C87	22 x 2270	2212	C180	22 x 4630	4572			
C88	22 x 2290	2232	C182	22 x 4680	4622			
C89	22 x 2320	2262	C184	22 x 4730	4672			
C90	22 x 2340	2282	C185	22 x 4750	4692			
C91	22 x 2370	2312	C190	22 x 4880	4822			
C92	22 x 2390	2332	C195	22 x 5010	4952			
C93	22 x 2420	2362	C200	22 x 5140	5082			
C94	22 x 2440	2382	C204	22 x 5240	5182			
C95	22 x 2470	2412	C208	22 x 5340	5282			
C96	22 x 2490	2432	C210	22 x 5390	5332			
C97	22 x 2520	2462	C214	22 x 5480	5422			
C98	22 x 2550	2492	C220	22 x 5640	5582			
C99	22 x 2580	2522	C224	22 x 5740	5682			
C100	22 x 2600	2542	C225	22 x 5770	5712			
C101	22 x 2630	2572	C228	22 x 5850	5792			
C102	22 x 2650	2592	C238	22 x 6100	6042			
C104	22 x 2700	2642	C240	22 x 6150	6092			
C105	22 x 2720	2662	C248	22 x 6360	6302			
C106	22 x 2750	2692	C250	22 x 6410	6352			
C108	22 x 2800	2742	C255	22 x 6540	6482			
C110	22 x 2850	2792	C256	22 x 6570	6512			

D 32 x 20

Imperial Li	Metric Lp	Metric Li	Imperial Li	Metric Lp	Metric Li
D90	32 x 2350	2275	D228	32 x 5870	5795
D97	32 x 2530	2455	D230	32 x 5920	5845
D98	32 x 2570	2495	D232	32 x 5980	5905
D101	32 x 2640	2565	D238	32 x 6130	6055
D102	32 x 2660	2585	D240	32 x 6180	6105
D105	32 x 2750	2675	D248	32 x 6380	6305
D108	32 x 2830	2755	D250	32 x 6430	6355
D109	32 x 2850	2775	D255	32 x 6560	6485
D110	32 x 2880	2805	D270	32 x 6940	6865
D112	32 x 2930	2855	D280	32 x 7190	7115
D113	32 x 2960	2885	D285	32 x 7320	7245
D120	32 x 3130	3055	D298	32 x 7650	7575
D124	32 x 3230	3155	D300	32 x 7700	7625
D128	32 x 3330	3255	D314	32 x 8060	7985
D130	32 x 3380	3305	D315	32 x 8090	8015
D132	32 x 3430	3355	D328	32 x 8410	8335
D136	32 x 3540	3465	D330	32 x 8460	8385
D137	32 x 3560	3485	D340	32 x 8710	8635
D140	32 x 3640	3565	D358	32 x 9170	9095
D144	32 x 3740	3665	D360	32 x 9220	9145
D148	32 x 3840	3765	D380	32 x 9730	9655
D150	32 x 3890	3815	D394	32 x 10080	10005
D152	32 x 3940	3865	D418	32 x 10700	10625
D154	32 x 3990	3915	D420	32 x 10740	10665
D156	32 x 4040	3965	D440	32 x 11250	11175
D158	32 x 4090	4015	D441	32 x 11270	11195
D162	32 x 4200	4125	D450	32 x 11500	11425
D166	32 x 4300	4225	D480	32 x 12260	12185
D170	32 x 4400	4325	D525	32 x 13410	13335
D173	32 x 4480	4405	D540	32 x 13790	13715
D177	32 x 4580	4505	D564	32 x 14400	14325
D180	32 x 4650	4575	D600	32 x 15310	15235
D185	32 x 4780	4705			
D187	32 x 4830	4755			
D191	32 x 4930	4855			
D195	32 x 5030	4955			
D204	32 x 5260	5185			
D210	32 x 5420	5345			
D220	32 x 5660	5585			
D225	32 x 5800	5725			

Every effort has been taken to ensure that the data listed in this catalogue is correct. Challenge accepts no liability for any inaccuracies or damage caused. All dimensions in millimetres unless otherwise stated.

Classical CRE V-Belts

AX 13 x 8

Imperial Li	Metric Lp	Metric Li	Imperial Li	Metric Lp	Metric Li
AX16	13 x 470	440	AX77	13 x 1990	1960
AX18	13 x 490	460	AX78	13 x 2020	1990
AX19	13 x 520	490	AX79	13 x 2050	2020
AX20	13 x 540	510	AX80	13 x 2070	2040
AX21	13 x 570	540	AX81	13 x 2090	2060
AX22	13 x 590	560	AX82	13 x 2120	2090
AX23	13 x 620	590	AX83	13 x 2140	2110
AX24	13 x 650	620	AX84	13 x 2170	2140
AX25	13 x 670	640	AX85	13 x 2190	2160
AX26	13 x 700	670	AX86	13 x 2220	2190
AX27	13 x 720	690	AX87	13 x 2240	2210
AX28	13 x 750	720	AX88	13 x 2270	2240
AX29	13 x 770	740	AX89	13 x 2300	2270
AX30	13 x 800	770	AX90	13 x 2320	2290
AX31	13 x 820	790	AX91	13 x 2350	2320
AX32	13 x 850	820	AX92	13 x 2370	2340
AX33	13 x 870	840	AX93	13 x 2400	2370
AX34	13 x 900	870	AX94	13 x 2420	2390
AX35	13 x 920	890	AX95	13 x 2450	2420
AX36	13 x 950	920	AX96	13 x 2470	2440
AX37	13 x 980	950	AX97	13 x 2500	2470
AX38	13 x 1000	970	AX98	13 x 2530	2500
AX39	13 x 1030	1000			
AX40	13 x 1050	1020			
AX41	13 x 1080	1050			
AX42	13 x 1100	1070			
AX43	13 x 1130	1100			
AX44	13 x 1150	1120			
AX45	13 x 1180	1150			
AX46	13 x 1200	1170			
AX47	13 x 1230	1200			
AX48	13 x 1250	1220			
AX49	13 x 1280	1250			
AX50	13 x 1310	1280			
AX51	13 x 1330	1300			
AX52	13 x 1360	1330			
AX53	13 x 1380	1350			
AX54	13 x 1410	1380			
AX55	13 x 1430	1400			
AX56	13 x 1460	1430			
AX57	13 x 1480	1450			
AX58	13 x 1510	1480			
AX59	13 x 1530	1500			
AX60	13 x 1560	1530			
AX61	13 x 1580	1550			
AX62	13 x 1610	1580			
AX63	13 x 1640	1610			
AX64	13 x 1660	1630			
AX65	13 x 1690	1660			
AX66	13 x 1710	1680			
AX67	13 x 1740	1710			
AX68	13 x 1760	1730			
AX69	13 x 1790	1760			
AX70	13 x 1810	1780			
AX71	13 x 1840	1810			
AX72	13 x 1860	1830			
AX73	13 x 1890	1860			
AX74	13 x 1920	1890			
AX75	13 x 1940	1910			
AX76	13 x 1960	1930			

BX 17 x 11

Imperial Li	Metric Lp	Metric Li	Imperial Li	Metric Lp	Metric Li
BX22	17 x 600	560	BX86	17 x 2230	2190
BX24	17 x 650	610	BX87	17 x 2250	2210
BX26	17 x 700	660	BX88	17 x 2280	2240
BX28	17 x 750	710	BX89	17 x 2300	2260
BX30	17 x 810	770	BX90	17 x 2330	2290
BX31	17 x 830	790	BX91	17 x 2350	2310
BX32	17 x 860	820	BX92	17 x 2380	2340
BX33	17 x 880	840	BX93	17 x 2410	2370
BX34	17 x 910	870	BX94	17 x 2420	2380
BX35	17 x 930	890			
BX36	17 x 960	920			
BX37	17 x 980	940			
BX38	17 x 1010	970			
BX39	17 x 1030	990			
BX40	17 x 1060	1020			
BX41	17 x 1080	1040			
BX42	17 x 1110	1070			
BX43	17 x 1130	1090			
BX44	17 x 1160	1120			
BX45	17 x 1180	1140			
BX46	17 x 1210	1170			
BX47	17 x 1240	1200			
BX48	17 x 1260	1220			
BX49	17 x 1290	1250			
BX50	17 x 1310	1270			
BX51	17 x 1340	1300			
BX52	17 x 1370	1330			
BX53	17 x 1390	1350			
BX54	17 x 1410	1370			
BX55	17 x 1440	1400			
BX56	17 x 1470	1430			
BX57	17 x 1490	1450			
BX58	17 x 1520	1480			
BX59	17 x 1540	1500			
BX60	17 x 1570	1530			
BX61	17 x 1590	1550			
BX62	17 x 1620	1580			
BX63	17 x 1640	1600			
BX64	17 x 1670	1630			
BX65	17 x 1690	1650			
BX66	17 x 1720	1680			
BX67	17 x 1740	1700			
BX68	17 x 1770	1730			
BX69	17 x 1800	1760			
BX70	17 x 1820	1780			
BX71	17 x 1850	1810			
BX72	17 x 1870	1830			
BX73	17 x 1900	1860			
BX74	17 x 1920	1880			
BX75	17 x 1950	1910			
BX76	17 x 1970	1930			
BX77	17 x 2000	1960			
BX78	17 x 2020	1980			
BX79	17 x 2050	2010			
BX80	17 x 2080	2040			
BX81	17 x 2100	2060			
BX82	17 x 2130	2090			
BX83	17 x 2150	2110			
BX84	17 x 2180	2140			
BX85	17 x 2200	2160			

All dimensions in millimetres unless otherwise stated. Every effort has been taken to ensure that the data listed in this catalogue is correct. Challenge accepts no liability for any inaccuracies or damage caused.

Wedge Belts

SPZ (10N) 10 x 8			SPA (13N) 13 x 10			SPB (16N) 16 x 13		SPC 22N 22 x 18
Metric Lp	Metric Lp	Metric Lp	Metric Lp	Metric Lp	Metric Lp	Metric Lp	Metric Lp	Metric Lp
512	1140	1887	632	1332	2300	1250	3500	2000
530	1162	1900	657	1357	2360	1260	3550	2120
545	1180	1937	682	1360	2430	1320	3600	2240
562	1187	1950	707	1362	2460	1340	3650	2360
580	1200	1962	732	1382	2482	1360	3750	2425
612	1212	2000	750	1400	2487	1400	3800	2450
630	1222	2030	757	1407	2500	1410	3900	2500
637	1237	2087	782	1432	2580	1450	4000	2650
662	1250	2120	800	1450	2607	1500	4060	2800
670	1262	2137	807	1457	2650	1550	4100	3000
687	1270	2150	825	1482	2720	1590	4250	3150
710	1287	2160	832	1500	2782	1600	4310	3350
737	1300	2187	850	1507	2800	1650	4500	3550
750	1312	2240	857	1532	2832	1700	4560	3750
760	1320	2280	875	1550	2847	1750	4710	4000
762	1337	2300	882	1557	2882	1800	4750	4100
772	1340	2360	900	1582	2900	1850	4820	4250
787	1347	2410	907	1600	2932	1900	5000	4500
797	1362	2500	925	1607	2982	1950	5070	4750
800	1387	2540	932	1632	3000	2000	5300	5000
812	1400	2650	950	1650	3150	2020	5380	5300
825	1412	2690	957	1657	3182	2060	5600	5600
837	1420	2800	975	1682	3350	2120	5680	6000
850	1437	2840	982	1700	3450	2150	5990	6300
862	1462	2990	1000	1707	3550	2200	6000	6700
875	1470	3000	1007	1732	3750	2240	6300	7000
887	1487	3150	1032	1750	4000	2280	6340	7100
900	1500	3170	1057	1757	4250	2300	6700	7500
912	1512	3350	1060	1782	4500	2350	7100	7750
925	1520	3550	1082	1800		2360	7500	8000
937	1537	3810	1090	1807		2400	8000	8500
940	1550		1107	1832		2410		9000
950	1560		1120	1857		2450		9500
962	1562		1132	1882		2500		10000
975	1587		1150	1900		2530		
987	1600		1157	1937		2550		
1000	1612		1180	1950		2600		
1010	1637		1182	1957		2650		
1012	1650		1200	1982		2680		
1020	1662		1207	2000		2700		
1037	1687		1220	2032		2800		
1060	1700		1232	2057		2840		
1062	1737		1250	2060		2990		
1080	1750		1257	2120		3000		
1087	1762		1272	2132		3150		
1090	1787		1280	2157		3170		
1100	1800		1282	2182		3270		
1112	1837		1300	2207		3320		
1120	1850		1307	2240		3340		
1137	1862		1320	2282		3350		

Equivalent belt designations are:

- 10N (SPZ) is interchangeable with 3V and 9N
- 16N (SPB) is interchangeable with 5V and 15N
- 25N (8V) is interchangeable with SPP

These do not apply to Banded belts

CRE Wedge Belts

SPZX 10 x 8		SPAX 13 x 10		SPBX 16 x 13	SPCX 22 x 18
Metric Lp	Metric Lp	Metric Lp	Metric Lp	Metric Lp	Metric Lp
587	1202	690	1500	1000	2240
600	1212	732	1507	1060	2360
612	1220	750	1522	1120	2650
630	1230	757	1532	1180	2800
637	1237	775	1550	1250	
660	1250	782	1557	1320	
662	1262	800	1582	1340	
670	1270	807	1600	1400	
687	1280	825	1607	1450	
690	1287	832	1632	1500	
710	1300	850	1650	1600	
722	1312	857	1682	1700	
730	1320	875	1700	1750	
737	1337	882	1732	1800	
750	1340	900	1750	1850	
760	1360	907	1757	1900	
762	1362	925	1782	1950	
772	1387	932	1800	1970	
775	1400	950	1832	2000	
787	1412	957	1850	2020	
800	1420	969	1900	2120	
812	1437	975	1950	2240	
817	1450	982	1957	2280	
825	1462	1000	1982	2360	
837	1470	1007	2000	2400	
850	1487	1030	2032	2410	
862	1500	1032	2057	2500	
875	1512	1060	2060	2650	
887	1520	1082	2120	2800	
900	1537	1090	2160		
912	1550	1107	2180		
917	1560	1120	2240		
925	1562	1132	2282		
937	1587	1142	2300		
950	1600	1150	2360		
962	1612	1157			
975	1650	1172			
987	1662	1180			
1000	1700	1207			
1010	1750	1220			
1012	1762	1232			
1030	1800	1250			
1037	1850	1257			
1040	1900	1272			
1047	1950	1280			
1057	2000	1282			
1060	2030	1307			
1077	2040	1320			
1080	2080	1332			
1087	2120	1357			
1110	2160	1360			
1112	2200	1380			
1120	2240	1382			
1137	2280	1400			
1140	2360	1420			
1150		1432			
1162		1450			
1180		1457			
1187		1462			
1200		1482			

All dimensions in millimetres unless otherwise stated. Every effort has been taken to ensure that the data listed in this catalogue is correct. Challenge accepts no liability for any inaccuracies or damage caused.

Narrow V Belts

3V (9N) 0.38 x 0.31	
Belt Designation	Effective Outside Length
3V250	25.0
3V265	26.5
3V280	28.0
3V300	30.0
3V315	31.5
3V335	33.5
3V355	35.5
3V375	37.5
3V400	40.0
3V425	42.5
3V450	45.0
3V475	47.5
3V500	50.0
3V530	53.0
3V560	56.0
3V600	60.0
3V630	63.0
3V670	67.0
3V710	71.0
3V750	75.0
3V800	80.0
3V850	85.0
3V900	90.0
3V950	95.0
3V1000	100.0
3V1060	106.0
3V1120	112.0
3V1180	118.0
3V1250	125.0
3V1320	132.0
3V1400	140.0

5V (15N) 0.62 x 0.53	
Belt Designation	Effective Outside Length
5V500	50
5V530	53
5V560	56
5V600	60
5V630	63
5V670	67
5V710	71
5V750	75
5V800	80
5V850	85
5V900	90
5V950	95
5V1000	100
5V1060	106
5V1120	112
5V1180	118
5V1250	125
5V1320	132
5V1400	140
5V1500	150
5V1600	160
5V1700	170
5V1800	180
5V1900	190
5V2000	200
5V2120	212
5V2240	224
5V2360	236
5V2500	250
5V2650	265
5V2800	280
5V3000	300
5V3150	315
5V3350	335
5V3550	355

8V (25N) 1.00 x 0.91	
Belt Designation	Effective Outside Length
8V1000	100
8V1060	106
8V1120	112
8V1180	118
8V1250	125
8V1320	132
8V1400	140
8V1500	150
8V1600	160
8V1700	170
8V1800	180
8V1900	190
8V2000	200
8V2120	212
8V2240	224
8V2360	236
8V2500	250
8V2650	265
8V2800	280
8V3000	300
8V3150	315
8V3350	335
8V3550	355
8V3750	375
8V4000	400
8V4250	425
8V4500	450
8V4750	475
8V5000	500

Selection Procedure

Wedge belt selection procedure

1) Service factor

Refer to Table 1 on page 140 and select a service factor appropriate to the drive conditions.

2) Design power

Multiply the machine absorbed power (kW) by the service factor to obtain the design power.

If the machine absorbed power is not known, use the prime mover power (kW).

The design power is used as a basis for selecting the drive.

3) Belt section

Refer to Table 2 on page 141.

Note the intersection of the speed of the faster shaft (on the horizontal scale) and the design power (on the vertical scale).

The point of intersection indicates the preferable belt section.

4) Speed ratio

Divide the rotational speed of the high speed shaft by that of the low speed shaft to obtain the speed ratio.

5) Pulley pitch diameters

For the chosen section from step 3), refer to Table 3 Speed ratios on pages 142 and 143, then select two pulleys* that match closely the required speed ratio from step 4).

*Note : the use of small pulleys can overload motor bearings. It is preferable to use larger driving pulleys if possible.

Most applications will allow for a driven speed tolerance of $\pm 2\%$.

6) Belt length

Calculate the required pitch length of belt required from the following formula :-

$$L = 2C + \frac{(D-d)^2}{4.C} + 1.57 (D + d)$$

Where L = pitch length of belt in mm
C = centre distance required in mm
d = small pulley pitch diameter in mm
D = large pulley pitch diameter in mm

From the list of belts (pages 135, 136), choose a belt nearest to the calculated value.

When a centre distance value is not specified, choose one equal to or exceeding the sum of the pulley diameters.

7) Centre distance

To obtain the approximate actual centre distance, divide the difference between the chosen belt and the belt length required from step 6) by 2.

If the chosen belt is longer, add the value to the required centre distance or if it is shorter, deduct the value from the required centre distance.

Note: This simple method is usually accurate to within 2 millimetres.

If a more accurate centre distance value is required, use the formulae below :-

$$C = A + \sqrt{A^2 - B}$$

$$\text{Where } A = \frac{L}{4} - 0.3935 (D + d)$$

$$\text{and } B = \frac{(D-d)^2}{8}$$

8) Power per belt (kW)

Refer to Table 4 power ratings (pages 144, 145) for the section of belt chosen.

Read across the top row to the small pulley pitch diameter chosen. Then read down to the speed of the faster shaft to obtain the power per belt in kW.

If necessary, interpolate for a more accurate value.

9) Power addition for speed ratio

Refer to the same pages as the power ratings.

Read across the top to the column which contains the speed ratio being used.

Then read down to the speed of the faster shaft to obtain the power addition for the speed ratio.

10) Correction factor for belt length

Refer to Table 5 on page 145 and note the correction factor for the length of belt chosen in step 6).

11) Correction factor for angle of contact on the small pulley

Refer to Table 6 on page 145 and calculate the value for $\frac{D-d}{C}$

From the value, choose the nearest correction factor.

12) Corrected power per belt (kW)

Add the power addition for speed ratio (step 9) to the power per belt (step 8).

Multiply the result by the correction factors for belt length (step 10) and angle of contact (step 11) to obtain the corrected power per belt.

13) number of belts required

Divide the design power (step 2) by the corrected power per belt (step 12) to obtain the number of belts required for the drive.

14) Shaft dimensions

From the pulley dimension Tables, (pages 159 to 171), check that the chosen pulleys have a taper bush that will accommodate the required shaft sizes.

Selection Procedure

Wedge Belt Selection Example

Design a Wedge belt drive from a 90kW, 1440 rev/min direct on line start electric motor to a Belt Conveyor which carries copper ore and absorbs 81 kW.

The conveyor has to run at 403 rev/min for 12 hours per day.

The required centre distance is 1200 mm. The motor shaft is 75 mm diameter and the conveyor shaft 105 mm diameter.

1) Service factor

From Table 1 on page 140, the service factor chosen for a non-uniformly loaded belt conveyor running for 12 hours per day and driven by a direct on line electric motor is **1.3**

2) Design power

$$81 \times 1.3 = \mathbf{105.3 \text{ kW}}$$

3) Belt section

From Table 2 on page 141, note the point of intersection of the design power of 105.3 kW (on the horizontal axis) and the speed of the faster shaft of 1440 rev/min (on the vertical axis).

The point of intersection indicates **SPB or SPC** section wedge belts. A point of intersection near the top of a band usually gives the most economical selection, in this case **SPB** is chosen.

4) Speed ratio

$$\frac{1440}{403} = \mathbf{3.57 : 1}$$

5) Pulley pitch diameters

From the SPB speed ratio Table 3 on page 143, pulley pitch diameters of 280 mm and 1000 mm match the speed ratio requirement of 3.57 : 1

The speed ratio of 1000/280 = 3.57 : 1 will give a driven speed of 403 rev/min.

6) Belt length

Using the following formula, calculate the length of belt required :-

$$\text{Belt length (L)} = 2 \times 1200 + \frac{(1000 - 280)^2}{4 \times 1200} + 1.57 \times (1000 + 280)$$

$$= 2400 + 108 + 2010$$

$$= \mathbf{4518 \text{ mm}}$$

from the SPB belt length Tables on page 135, the nearest belt is an SPB4500

7) Centre distance

The **SPB4500** will give a centre distance of :-

$$1200 - \frac{(4518 - 4500)}{2} = \mathbf{1191 \text{ mm}}$$

8) Power per belt (kW)

From the SPB power ratings on Table 4 page 144, the power per belt for a 280mm pulley running at 1440 rev/min is **22.55 kW**

9) Power addition for speed ratio

From the same page as the power ratings, the power addition for the speed ratio of 3.57 : 1 is **1.21 kW**

10) Correction factor for belt length

From Table 5 on page 145, the correction factor for an SPB4500 is **1.05**

11) Correction factor for angle of contact

$$\text{First, calculate } \frac{D-d}{C}$$

and then refer to Table 6 on page 145 to obtain the correction factor.

$$\frac{D-d}{C} = \frac{1000 - 280}{1191} = 0.60$$

the correction factor is **0.96**

12) Corrected power per belt (kW)

$$= (22.55 + 1.21) \times 1.05 \times 0.96$$

$$= \mathbf{23.95 \text{ kW per belt}}$$

13) Number of belts required

Divide the design power (step 2) by the corrected power/belt (step 12) to obtain the number of belts required.

$$\frac{105.3}{23.95} = 4.4$$

use 5 SPB belts

14) Shaft dimensions

From the SPB pulley dimension Tables (pages 166 to 168), it is confirmed that the pulleys taper bushes can accommodate the required shaft sizes.

Drive Specification

Motor pulley :	280 x 5 SPB 3535 / 75 mm
Conveyor pulley	1000 x 5 SPB 4545 / 105 mm

5 off SPB4500 giving 1191 mm centres

Selection Data

Table 1 - Service Factors

Type of driven machine	Type of prime mover					
	'Soft' Starts			'Heavy' Starts		
	AC electric motors: star-delta DC motors: shunt wound Engines with 4 or more cylinders All prime movers with mechanical or electronic soft start devices.			AC electric motors :- direct – on – line DC motors : series and compound wound Engines with less than 4 cylinders		
	number of hours per day running					
	under 10	10 - 16	over 16	under 10	10 - 16	over 16
Uniform load: Light duty agitators, belt conveyors for sand etc., fans upto 7.5 kW, centrifugal compressors and pumps,	1.0	1.1	1.2	1.1	1.2	1.3
Moderate load: Variable density agitators, belt conveyors (non-uniform loads), fans over 7.5 kW, other rotary compressors and pumps, generators, machine tools, printing machinery, laundry machinery, rotary screens, rotary woodworking machinery	1.1	1.2	1.3	1.2	1.3	1.4
Heavy load: Reciprocating compressors and pumps, positive displacement blowers, heavy duty conveyors such as screw, bucket etc., hammer mills, pulverisers, presses, shears, punches, rubber machinery	1.2	1.3	1.4	1.4	1.5	1.6
Severe load: Crushers – gyratory, jaw, roll etc., rolling mills, calenders, quarry machinery, vibrating screens	1.3	1.4	1.5	1.5	1.6	1.8

All dimensions in millimetres unless otherwise stated. Every effort has been taken to ensure that the data listed in this catalogue is correct. Challenge accepts no liability for any inaccuracies or damage caused.

Selection Data

Table 2 - Belt Section

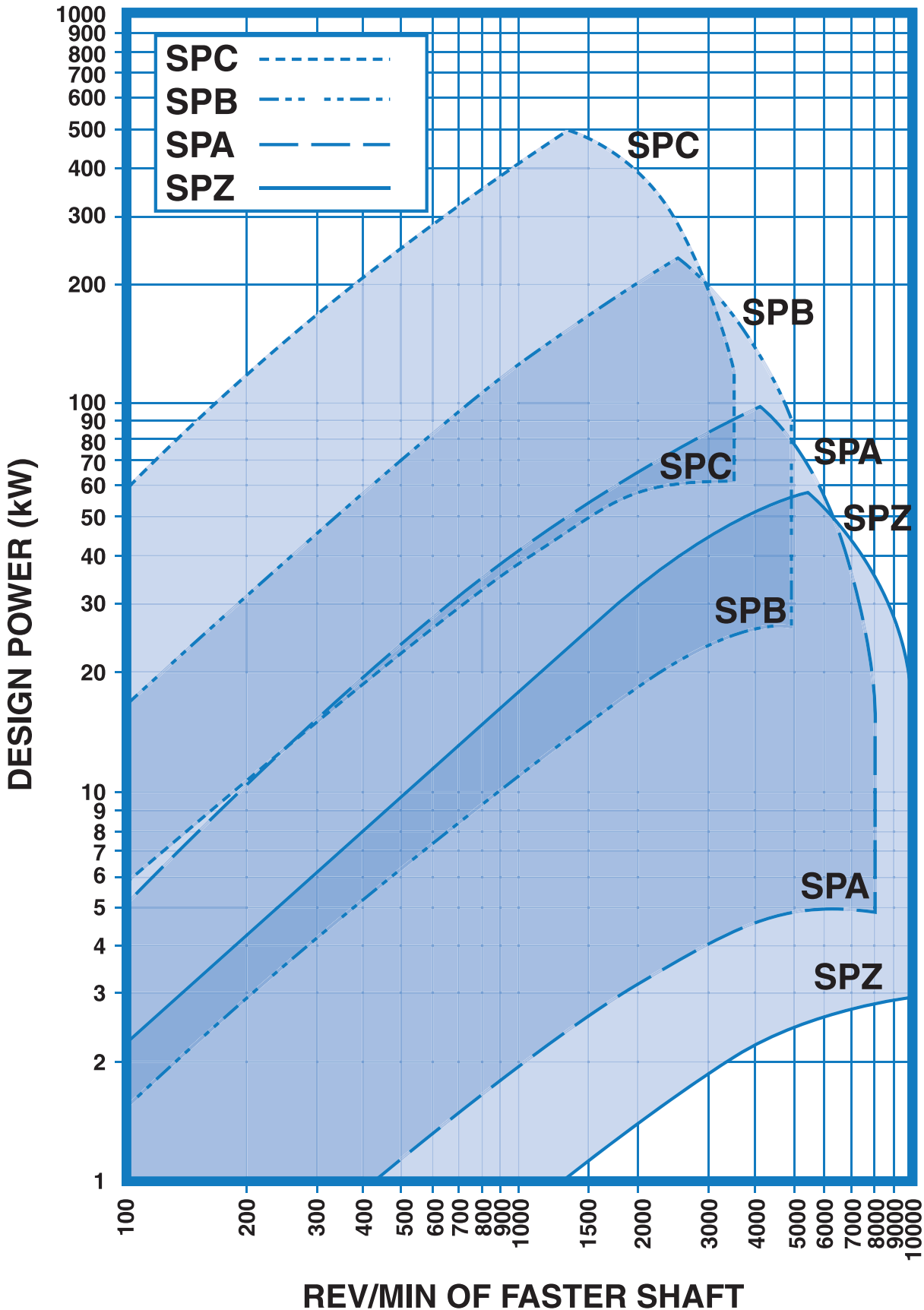

Every effort has been taken to ensure that the data listed in this catalogue is correct. Challenge accepts no liability for any inaccuracies or damage caused.

Selection Data

Table 3 - Speed ratios SPZ & SPA

SPZ	71	75	80	85	90	95	100	106	112	118	125	132	140
71	1.00												
75	1.06	1.00											
80	1.13	1.07	1.00										
85	1.20	1.13	1.06	1.00									
90	1.27	1.20	1.13	1.06	1.00								
95	1.34	1.27	1.19	1.12	1.06	1.00							
100	1.41	1.33	1.25	1.18	1.11	1.05	1.00						
106	1.49	1.41	1.33	1.25	1.18	1.12	1.06	1.00					
112	1.58	1.49	1.40	1.32	1.24	1.18	1.12	1.06	1.00				
118	1.66	1.57	1.48	1.39	1.31	1.24	1.18	1.11	1.05	1.00			
125	1.76	1.67	1.56	1.47	1.39	1.32	1.25	1.18	1.12	1.06	1.00		
132	1.86	1.76	1.65	1.55	1.47	1.39	1.32	1.25	1.18	1.12	1.06	1.00	
140	1.97	1.87	1.75	1.65	1.56	1.47	1.40	1.32	1.25	1.19	1.12	1.06	1.00
150	2.11	2.00	1.88	1.76	1.67	1.58	1.50	1.42	1.34	1.27	1.20	1.14	1.07
160	2.25	2.13	2.00	1.88	1.78	1.68	1.60	1.51	1.43	1.36	1.28	1.21	1.14
170	2.39	2.27	2.13	2.00	1.89	1.79	1.70	1.60	1.52	1.44	1.36	1.29	1.21
180	2.54	2.40	2.25	2.12	2.00	1.89	1.80	1.70	1.61	1.53	1.44	1.36	1.29
190	2.68	2.53	2.38	2.24	2.11	2.00	1.90	1.79	1.70	1.61	1.52	1.44	1.36
200	2.82	2.67	2.50	2.35	2.22	2.11	2.00	1.89	1.79	1.69	1.60	1.52	1.43
224	3.15	2.99	2.80	2.64	2.49	2.36	2.24	2.11	2.00	1.90	1.79	1.70	1.60
250	3.52	3.33	3.13	2.94	2.78	2.63	2.50	2.36	2.23	2.12	2.00	1.89	1.79
280	3.94	3.73	3.50	3.29	3.11	2.95	2.80	2.64	2.50	2.37	2.24	2.12	2.00
315	4.44	4.20	3.94	3.71	3.50	3.32	3.15	2.97	2.81	2.67	2.52	2.39	2.25
355	5.00	4.73	4.44	4.18	3.94	3.74	3.55	3.35	3.17	3.01	2.84	2.69	2.54
400	5.63	5.33	5.00	4.71	4.44	4.21	4.00	3.77	3.57	3.39	3.20	3.03	2.86
450	6.34	6.00	5.63	5.29	5.00	4.74	4.50	4.25	4.02	3.81	3.60	3.41	3.21
500	7.04	6.67	6.25	5.88	5.56	5.26	5.00	4.72	4.46	4.24	4.00	3.79	3.57
630	8.87	8.40	7.88	7.41	7.00	6.63	6.30	5.94	5.63	5.34	5.04	4.77	4.50

SPA	90	95	100	106	112	118	125	132	140	150	160	170	180	190	200
90	1.00														
95	1.06	1.00													
100	1.11	1.05	1.00												
106	1.18	1.12	1.06	1.00											
112	1.24	1.18	1.12	1.06	1.00										
118	1.31	1.24	1.18	1.11	1.05	1.00									
125	1.39	1.32	1.25	1.18	1.12	1.06	1.00								
132	1.47	1.39	1.32	1.25	1.18	1.12	1.06	1.00							
140	1.56	1.47	1.40	1.32	1.25	1.19	1.12	1.06	1.00						
150	1.67	1.58	1.50	1.42	1.34	1.27	1.20	1.14	1.07	1.00					
160	1.78	1.68	1.60	1.51	1.43	1.36	1.28	1.21	1.14	1.07	1.00				
170	1.89	1.79	1.70	1.60	1.52	1.44	1.36	1.29	1.21	1.13	1.06	1.00			
180	2.00	1.89	1.80	1.70	1.61	1.53	1.44	1.36	1.29	1.20	1.13	1.06	1.00		
190	2.11	2.00	1.90	1.79	1.70	1.61	1.52	1.44	1.36	1.27	1.19	1.12	1.06	1.00	
200	2.22	2.11	2.00	1.89	1.79	1.69	1.60	1.52	1.43	1.33	1.25	1.18	1.11	1.05	1.00
212	2.36	2.23	2.12	2.00	1.89	1.80	1.70	1.61	1.51	1.41	1.33	1.25	1.18	1.12	1.06
224	2.49	2.36	2.24	2.11	2.00	1.90	1.79	1.70	1.60	1.49	1.40	1.32	1.24	1.18	1.12
236	2.62	2.48	2.36	2.23	2.11	2.00	1.89	1.79	1.69	1.57	1.48	1.39	1.31	1.24	1.18
250	2.78	2.63	2.50	2.36	2.23	2.12	2.00	1.89	1.79	1.67	1.56	1.47	1.39	1.32	1.25
280	3.11	2.95	2.80	2.64	2.50	2.37	2.24	2.12	2.00	1.87	1.75	1.65	1.56	1.47	1.40
300	3.33	3.16	3.00	2.83	2.68	2.54	2.40	2.27	2.14	2.00	1.88	1.76	1.67	1.58	1.50
315	3.50	3.32	3.15	2.97	2.81	2.67	2.52	2.39	2.25	2.10	1.97	1.85	1.75	1.66	1.58
355	3.94	3.74	3.55	3.35	3.17	3.01	2.84	2.69	2.54	2.37	2.22	2.09	1.97	1.87	1.78
400	4.44	4.21	4.00	3.77	3.57	3.39	3.20	3.03	2.86	2.67	2.50	2.35	2.22	2.11	2.00
450	5.00	4.74	4.50	4.25	4.02	3.81	3.60	3.41	3.21	3.00	2.81	2.65	2.50	2.37	2.25
500	5.56	5.26	5.00	4.72	4.46	4.24	4.00	3.79	3.57	3.33	3.13	2.94	2.78	2.63	2.50
560	6.22	5.89	5.60	5.28	5.00	4.75	4.48	4.24	4.00	3.73	3.50	3.29	3.11	2.95	2.80
630	7.00	6.63	6.30	5.94	5.63	5.34	5.04	4.77	4.50	4.20	3.94	3.71	3.50	3.32	3.15
800	8.89	8.42	8.00	7.55	7.14	6.78	6.40	6.06	5.71	5.33	5.00	4.71	4.44	4.21	4.00

All dimensions in millimetres unless otherwise stated. Every effort has been taken to ensure that the data listed in this catalogue is correct. Challenge accepts no liability for any inaccuracies or damage caused.

Selection Data

Table 3 - Speed ratios SPB & SPC

SPB	140	150	160	170	180	190	200	212	224	236	250	280	300	315
140	1.00													
150	1.07	1.00												
160	1.14	1.07	1.00											
170	1.21	1.13	1.06	1.00										
180	1.29	1.20	1.13	1.06	1.00									
190	1.36	1.27	1.19	1.12	1.06	1.00								
200	1.43	1.33	1.25	1.18	1.11	1.05	1.00							
212	1.51	1.41	1.33	1.25	1.18	1.12	1.06	1.00						
224	1.60	1.49	1.40	1.32	1.24	1.18	1.12	1.06	1.00					
236	1.69	1.57	1.48	1.39	1.31	1.24	1.18	1.11	1.05	1.00				
250	1.79	1.67	1.56	1.47	1.39	1.32	1.25	1.18	1.12	1.06	1.00			
280	2.00	1.87	1.75	1.65	1.56	1.47	1.40	1.32	1.25	1.19	1.12	1.00		
300	2.14	2.00	1.88	1.76	1.67	1.58	1.50	1.42	1.34	1.27	1.20	1.07	1.00	
315	2.25	2.10	1.97	1.85	1.75	1.66	1.58	1.49	1.41	1.33	1.26	1.13	1.05	1.00
335	2.39	2.23	2.09	1.97	1.86	1.76	1.68	1.58	1.50	1.42	1.34	1.20	1.12	1.06
355	2.54	2.37	2.22	2.09	1.97	1.87	1.78	1.67	1.58	1.50	1.42	1.27	1.18	1.13
400	2.86	2.67	2.50	2.35	2.22	2.11	2.00	1.89	1.79	1.69	1.60	1.43	1.33	1.27
450	3.21	3.00	2.81	2.65	2.50	2.37	2.25	2.12	2.01	1.91	1.80	1.61	1.50	1.43
500	3.57	3.33	3.13	2.94	2.78	2.63	2.50	2.36	2.23	2.12	2.00	1.79	1.67	1.59
560	4.00	3.73	3.50	3.29	3.11	2.95	2.80	2.64	2.50	2.37	2.24	2.00	1.87	1.78
630	4.50	4.20	3.94	3.71	3.50	3.32	3.15	2.97	2.81	2.67	2.52	2.25	2.10	2.00
710	5.07	4.73	4.44	4.18	3.94	3.74	3.55	3.35	3.17	3.01	2.84	2.54	2.37	2.25
800	5.71	5.33	5.00	4.71	4.44	4.21	4.00	3.77	3.57	3.39	3.20	2.86	2.67	2.54
900	6.43	6.00	5.63	5.29	5.00	4.74	4.50	4.25	4.02	3.81	3.60	3.21	3.00	2.86
1000	7.14	6.67	6.25	5.88	5.56	5.26	5.00	4.72	4.46	4.24	4.00	3.57	3.33	3.17
1250	8.93	8.33	7.81	7.35	6.94	6.58	6.25	5.90	5.58	5.30	5.00	4.46	4.17	3.97

SPC	224	236	250	265	280	300	315	335	355	375	400	425	450	475	500	530	560
224	1.00																
236	1.05	1.00															
250	1.12	1.06	1.00														
265	1.18	1.12	1.06	1.00													
280	1.25	1.19	1.12	1.06	1.00												
300	1.34	1.27	1.20	1.13	1.07	1.00											
315	1.41	1.33	1.26	1.19	1.13	1.05	1.00										
335	1.50	1.42	1.34	1.26	1.20	1.12	1.06	1.00									
355	1.58	1.50	1.42	1.34	1.27	1.18	1.13	1.06	1.00								
375	1.67	1.59	1.50	1.42	1.34	1.25	1.19	1.12	1.06	1.00							
400	1.79	1.69	1.60	1.51	1.43	1.33	1.27	1.19	1.13	1.07	1.00						
425	1.90	1.80	1.70	1.60	1.52	1.42	1.35	1.27	1.20	1.13	1.06	1.00					
450	2.01	1.91	1.80	1.70	1.61	1.50	1.43	1.34	1.27	1.20	1.13	1.06	1.00				
475	2.12	2.01	1.90	1.79	1.70	1.58	1.51	1.42	1.34	1.27	1.19	1.12	1.06	1.00			
500	2.23	2.12	2.00	1.89	1.79	1.67	1.59	1.49	1.41	1.33	1.25	1.18	1.11	1.05	1.00		
530	2.37	2.25	2.12	2.00	1.89	1.77	1.68	1.58	1.49	1.41	1.33	1.25	1.18	1.12	1.06	1.00	
560	2.50	2.37	2.24	2.11	2.00	1.87	1.78	1.67	1.58	1.49	1.40	1.32	1.24	1.18	1.12	1.06	1.00
630	2.81	2.67	2.52	2.38	2.25	2.10	2.00	1.88	1.77	1.68	1.58	1.48	1.40	1.33	1.26	1.19	1.13
710	3.17	3.01	2.84	2.68	2.54	2.37	2.25	2.12	2.00	1.89	1.78	1.67	1.58	1.49	1.42	1.34	1.27
800	3.57	3.39	3.20	3.02	2.86	2.67	2.54	2.39	2.25	2.13	2.00	1.88	1.78	1.68	1.60	1.51	1.43
1000	4.46	4.24	4.00	3.77	3.57	3.33	3.17	2.99	2.82	2.67	2.50	2.35	2.22	2.11	2.00	1.89	1.79
1250	5.58	5.30	5.00	4.72	4.46	4.17	3.97	3.73	3.52	3.33	3.13	2.94	2.78	2.63	2.50	2.36	2.23

Every effort has been taken to ensure that the data listed in this catalogue is correct. Challenge accepts no liability for any inaccuracies or damage caused. All dimensions in millimetres unless otherwise stated.

Selection Data

Table 4 - Power ratings

SPZ Power ratings (kW)									Power addition (kW) for speed ratio				
rev/min	71	75	80	90	100	112	125	140	1.00 - 1.05	1.06 - 1.25	1.26 - 2.00	2.01 - 3.00	over 3.00
400	0.51	0.57	0.63	0.76	0.91	1.08	1.25	1.47	0.00	0.04	0.07	0.07	0.07
600	0.70	0.78	0.89	1.08	1.30	1.55	1.82	2.12	0.00	0.05	0.08	0.08	0.08
720	0.82	0.89	1.04	1.28	1.54	1.83	2.15	2.50	0.00	0.06	0.10	0.11	0.12
800	0.88	0.99	1.14	1.41	1.68	2.00	2.35	2.74	0.00	0.07	0.11	0.12	0.13
960	1.01	1.16	1.33	1.66	1.96	2.34	2.74	3.23	0.00	0.08	0.13	0.15	0.15
1200	1.23	1.40	1.60	2.01	2.38	2.87	3.37	3.93	0.00	0.10	0.17	0.17	0.19
1440	1.45	1.63	1.86	2.34	2.80	3.38	3.98	4.62	0.00	0.13	0.20	0.22	0.23
1600	1.57	1.76	2.03	2.56	3.06	3.68	4.33	5.05	0.00	0.14	0.22	0.24	0.26
2000	1.87	2.10	2.43	3.08	3.70	4.42	5.20	6.09	0.00	0.17	0.28	0.30	0.32
2400	2.13	2.43	2.80	3.55	4.27	5.10	5.99	7.00	0.00	0.21	0.33	0.36	0.39
2800	2.38	2.74	3.15	4.00	4.81	5.76	6.75	7.88	0.00	0.24	0.39	0.43	0.45
2880	2.43	2.80	3.22	4.09	4.92	5.89	6.90	8.05	0.00	0.25	0.40	0.44	0.45
3200	2.62	3.01	3.48	4.41	5.32	6.36	7.43	8.65	0.00	0.28	0.45	0.49	0.51
3600	2.85	3.26	3.80	4.80	5.80	6.92	8.07	9.35	0.00	0.31	0.50	0.55	0.58
4000	3.03	3.47	4.06	5.14	6.20	7.38	8.58	9.86	0.00	0.35	0.56	0.61	0.64
4500	3.25	3.72	4.37	5.54	6.67	7.92	9.17	10.42	0.00	0.39	0.62	0.68	0.72
5000	3.44	3.96	4.62	5.87	7.05	8.32	9.56	10.79	0.00	0.44	0.70	0.73	0.77

SPA Power ratings (kW)											Power addition (kW) for speed ratio				
rev/min	90	100	112	118	125	132	140	160	180	200	1.00 - 1.05	1.06 - 1.25	1.26 - 2.00	2.01 - 3.00	over 3.00
400	0.87	1.11	1.43	1.56	1.73	1.90	2.09	2.59	3.06	3.55	0.00	0.07	0.14	0.16	0.16
600	1.20	1.55	1.99	2.19	2.44	2.69	2.97	3.66	4.35	5.02	0.00	0.13	0.21	0.23	0.25
720	1.40	1.81	2.32	2.57	2.86	3.15	3.48	4.30	5.11	5.88	0.00	0.16	0.26	0.28	0.30
800	1.50	1.97	2.54	2.81	3.13	3.44	3.81	4.72	5.61	6.47	0.00	0.18	0.29	0.31	0.33
960	1.72	2.28	2.96	3.30	3.66	4.04	4.47	5.55	6.59	7.62	0.00	0.21	0.34	0.37	0.40
1200	2.04	2.72	3.55	3.98	4.42	4.88	5.41	6.72	7.99	9.24	0.00	0.27	0.43	0.47	0.49
1440	2.35	3.15	4.12	4.64	5.17	5.71	6.33	7.86	9.35	10.81	0.00	0.32	0.51	0.56	0.59
1600	2.53	3.41	4.47	5.02	5.60	6.19	6.87	8.54	10.14	11.72	0.00	0.36	0.57	0.62	0.66
2000	2.98	4.03	5.33	5.95	6.66	7.38	8.20	10.18	12.04	13.92	0.00	0.45	0.71	0.78	0.82
2400	3.31	4.56	6.04	6.76	7.58	8.39	9.32	11.52	13.61	15.60	0.00	0.54	0.86	0.93	0.99
2800	3.66	5.11	6.78	7.61	8.54	9.45	10.48	12.91	15.21	17.29	0.00	0.63	1.00	1.09	1.15
2880	3.68	5.16	6.84	7.68	8.62	9.53	10.57	13.02	15.34	17.42	0.00	0.64	1.03	1.12	1.19
3200	3.88	5.47	7.27	8.18	9.18	10.15	11.23	13.76	16.09	18.51	0.00	0.72	1.14	1.25	1.32
3600	4.11	5.83	7.77	8.76	9.83	10.85	12.00	14.60	16.91	19.71	0.00	0.81	1.29	1.40	1.48

SPB Power ratings (kW)										Power addition (kW) for speed ratio					
rev/min	140	160	180	200	224	236	250	280	315	1.00 - 1.05	1.06 - 1.25	1.26 - 2.00	2.01 - 3.00	over 3.00	
200	1.40	1.79	2.19	2.57	3.06	3.28	3.52	4.12	4.78		0.00	0.09	0.15	0.16	0.17
400	2.52	3.29	4.02	4.78	5.66	6.10	6.61	7.70	8.92		0.00	0.19	0.29	0.32	0.34
600	3.50	4.60	5.65	6.73	7.98	8.50	9.33	10.88	12.62		0.00	0.28	0.45	0.48	0.51
720	4.08	5.36	6.61	7.88	9.34	9.90	10.93	12.75	14.78		0.00	0.33	0.54	0.59	0.62
800	4.45	5.87	7.23	8.63	10.24	10.94	11.98	13.97	16.18		0.00	0.37	0.60	0.65	0.69
960	5.19	6.85	8.48	10.12	12.03	13.00	14.04	16.37	18.94		0.00	0.44	0.70	0.77	0.81
1200	6.17	8.20	10.18	12.15	14.45	15.61	16.84	19.53	22.53		0.00	0.56	0.89	0.97	1.03
1440	7.13	9.50	11.84	14.11	16.79	18.12	19.53	22.55	25.93		0.00	0.66	1.06	1.15	1.21
1600	7.66	10.25	12.77	15.20	18.04	19.46	20.96	24.14	27.56		0.00	0.75	1.19	1.29	1.37
1800	8.31	11.16	13.89	16.52	19.56	21.07	22.67	26.01	29.47		0.00	0.84	1.34	1.45	1.54
2000	8.94	12.04	14.97	17.80	21.00	22.60	24.29	27.76	31.21		0.00	0.93	1.48	1.62	1.71
2400	9.91	13.37	16.59	19.63	23.15	24.55	26.83	29.45	31.95		0.00	1.11	1.78	1.94	2.05
2880	10.95	14.78	18.29	21.51	25.29	26.39	29.29	-	-		0.00	1.32	2.11	2.31	2.44
3000	11.11	15.01	18.56	21.75	25.45	26.53	29.42	-	-		0.00	1.39	2.23	2.42	2.57

All dimensions in millimetres unless otherwise stated. Every effort has been taken to ensure that the data listed in this catalogue is correct. Challenge accepts no liability for any inaccuracies or damage caused.

Selection Data

Table 4 - Power ratings (continued)

SPC Power ratings (kW)														Power addition (kW) for speed ratio				
rev/min	224	236	250	265	280	300	315	335	355	400	450	500	560	1.00-1.05	1.06-1.25	1.26-2.00	2.01-3.00	over 3.00
200	3.99	4.47	4.95	5.27	6.04	6.71	7.30	8.09	8.73	10.34	12.06	13.81	15.87	0.00	0.29	0.46	0.50	0.53
400	7.16	8.04	8.98	10.02	11.05	12.28	13.40	14.78	16.15	19.09	22.40	25.59	29.40	0.00	0.57	0.92	1.00	1.06
600	9.86	11.04	12.43	13.99	15.35	17.14	18.71	20.63	22.52	26.65	31.17	35.57	40.66	0.00	0.86	1.37	1.50	1.59
720	11.41	12.77	14.43	16.29	17.84	19.95	21.79	24.03	26.20	31.02	36.21	41.27	47.04	0.00	1.03	1.65	1.80	1.90
800	12.41	13.84	15.71	17.66	19.46	21.74	23.75	26.18	28.54	33.76	39.32	44.33	50.77	0.00	1.15	1.83	2.00	2.11
960	14.34	15.93	18.20	20.33	22.59	25.23	27.56	30.36	33.08	39.06	45.29	50.11	57.80	0.00	1.37	2.20	2.40	2.54
1200	16.78	18.78	21.36	23.73	26.53	29.62	32.29	35.41	38.55	45.07	51.63	56.89	63.01	0.00	1.72	2.75	3.00	3.17
1440	19.05	21.44	24.30	26.88	30.17	33.67	36.63	40.02	43.49	50.36	56.96	62.32	-	0.00	2.06	3.30	3.60	3.81
1600	20.14	22.92	25.82	28.93	29.55	35.57	38.64	42.18	45.58	52.35	58.09	-	-	0.00	2.29	3.67	4.00	4.23
1800	21.39	24.30	27.39	30.63	33.82	37.51	40.66	44.04	47.43	53.97	-	-	-	0.00	2.58	4.12	4.50	4.76
2000	22.25	25.33	28.53	31.82	35.09	38.74	41.82	45.08	48.40	-	-	-	-	0.00	2.86	4.58	5.00	5.29

Table 5 - Correction factors for belt length

SPZ		SPA		SPB		SPC	
Belt length (mm)	Correction factor	Belt length (mm)	Correction factor	Belt length (mm)	Correction factor	Belt length (mm)	Correction factor
510 - 710	0.80	750 - 900	0.80	1250 - 1340	0.80	2000 - 2240	0.80
737 - 950	0.85	925 - 1120	0.85	1400 - 1600	0.85	2360 - 2800	0.85
962 - 1250	0.90	1132 - 1600	0.90	1650 - 2240	0.90	3000 - 3350	0.90
1270 - 1500	0.95	1632 - 2240	0.95	2280 - 3000	0.95	3550 - 4500	0.95
1520 - 2120	1.00	2300 - 2800	1.00	3150 - 3750	1.00	4750 - 5600	1.00
2150 - 2840	1.05	2900 - 3550	1.05	3800 - 5000	1.05	6000 - 8000	1.05
2990 - 3810	1.10	3750 - 4500	1.10	5070 - 7990	1.10	8500 - 10000	1.10

Table 6 - correction factors for angle of contact on small pulley

$\frac{D-d}{C}$	Angle of contact	Correction factor	$\frac{D-d}{C}$	Angle of contact	Correction factor
0.00	180°	1.00	0.80	133°	0.94
0.10	174°	0.99	0.90	127°	0.92
0.20	169°	0.99	1.00	120°	0.91
0.30	163°	0.98	1.10	113°	0.89
0.40	157°	0.98	1.20	106°	0.87
0.50	151°	0.97	1.30	99°	0.85
0.60	145°	0.96	1.40	91°	0.82
0.70	139°	0.95	1.45	87°	0.80



Edisonweg 5
 4631SN Hoogerheide
 0164-611000
 techniek@overveldtechniek.com
 www.overveldtechniek.com



Belt Tensioning

Challenge 'V' and Wedge belts are manufactured to ensure precise length and to stay matched during storage and on the drive for many years. This also ensures that each belt, when correctly tensioned, will take the correct share of the load to be transmitted, thus helping to achieve maximum life for the drive.

We recommend using the CHALLENGE Belt Tensioning Gauge to obtain the correct tension for the drive thus ensuring optimum life from the belts. This method has been verified by successful drives globally

Method of belt tensioning using the CHALLENGE Belt Tension Gauge

- 1] Install the belts to be a snug fit around the pulleys
 - 2] Rotate the pulleys a few revolutions to allow the belts to sit correctly in the pulley grooves. Be careful not to trap fingers !
 - 3] Calculate the deflection in mm on a basis of 16 mm per metre of centre distance
 - 4] Set the lower black rubber ring on the large tube to the deflection required in mm
 - 5] Set the upper ring (on the metal rod) against the top of the large tube
 - 6] Place the belt tension indicator on top of the belt at the middle of the centre distance and apply a force at right angles to the belt, deflecting it to the point where the lower rubber ring is level with the top of an adjacent belt.
 - 7] Read off the tensioning force value indicated by the bottom edge of the upper rubber ring
 - 8] Compare this force to the value in the table and adjust the tension until the correct value is attained
 - 9] A new drive should be tensioned to the 1.3 x tensioning force to allow for belt tension decay during the initial bedding in period.
- After approximately 30 minutes of running and thereafter, the tension should be set to the basic tensioning value
- 10] For a single belt drive, use a straight edge across the two pulleys to act as a reference point and apply the CHALLENGE Belt Tension Gauge as per point 6.
 - 11] If a CHALLENGE Belt Tension Gauge is not available, using a spring balance and rule is acceptable.

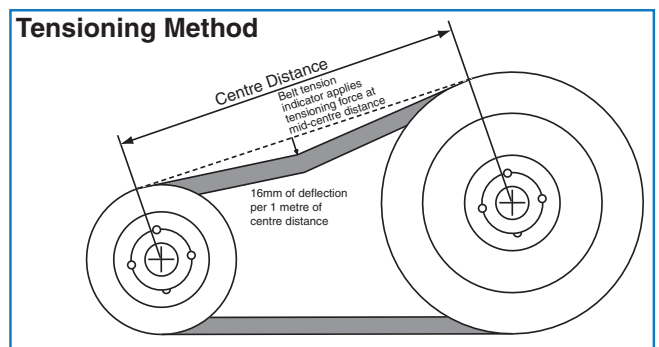

Belt Tension Indicator

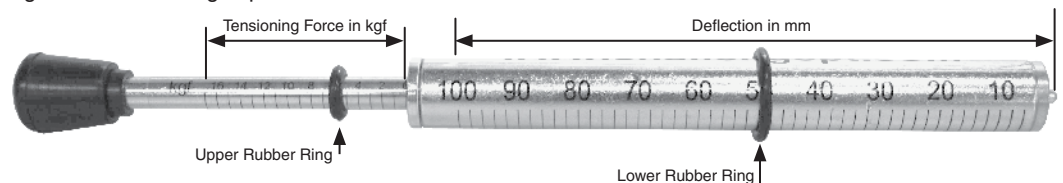

Tensioning forces

Belt section	Tensioning force to deflect belt 16 mm per metre of centre distance		
	Small pulley diameter (mm)	Basic tensioning forces (kgf)	1.3 x tensioning forces (kgf)
SPZ	56 – 71	1.6	2.1
	75 – 90	1.8	2.3
	90 – 125	2.0	2.6
	125 +	2.1	2.7
SPA	63 – 100	2.2	2.8
	106 – 140	3.0	3.9
	150 – 200	3.7	4.8
	200 +	4.0	5.2
SPB	100 – 160	4.0	5.2
	170 – 224	5.1	6.6
	236 – 355	6.3	8.2
	355 +	6.6	8.6
SPC	200 – 250	7.1	9.2
	265 – 355	9.4	12.2
	375 +	12.0	15.6
Z	56 – 100	0.5 – 0.8	0.6 – 1.0
A	80 – 140	1.0 – 1.5	1.3 – 1.9
B	125 – 200	2.0 – 3.1	2.6 – 4.0
C	200 – 400	4.1 – 6.1	5.5 – 7.9
D	355 – 600	7.1 – 10.7	9.2 – 13.9

The tensioning forces in the table above are representative for a correctly designed drive. A precise tensioning force for a particular drive can be calculated from basic principles if desired. Contact Challenge for details

All dimensions in millimetres unless otherwise stated. Every effort has been taken to ensure that the data listed in this catalogue is correct. Challenge accepts no liability for any inaccuracies or damage caused.