

 **CHALLENGE**  [®]

 OverveldTechniek

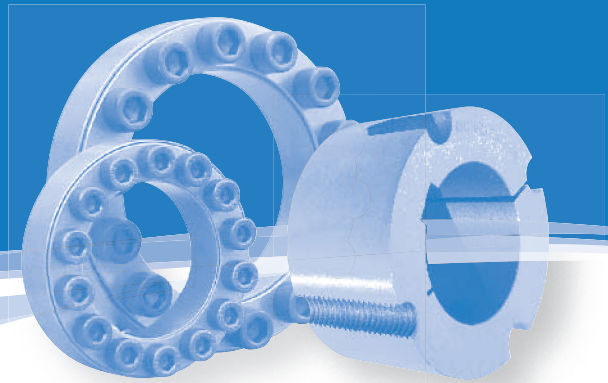



Features

Taper Bushes

- Challenge '3 hole' bushes have a 4th hole as standard for optimum balancing
- Easy installation and removal
- No re-boring as a full range of both metric and inch bores are available
- Totally proven bush system. Millions in use world wide
- Fit standard shafts
- Quality screws used
- Keys not required on light duty applications
- Short length bushes allow increased maximum bores
- Superior packaging complete with fitting instructions

Adaptors

- Allows pilot bore products to be adapted for taper bush use
- Avoids the need to drill, tap and taper bore
- Plain outside diameter or keyed are available
- Conform to all major international standards

Bolt-on-Hubs

- Designed to accept the universally popular taper bush
- A convenient way in which products such as fan rotors, impellers etc can be converted to accept taper bushes without welding

Weld-on-Hubs

- Manufactured from low carbon steel and designed to accept taper bushes
- Provide a convenient means of welding hubs into fan rotors, plate sprockets etc.
- Three different designs available

Cone Clamping Elements

- Premium grade quality with high machining tolerances and surface finishes
- Wide range of sizes and configurations
- Keyless design
- Simple installation and ease of removal
- Zero backlash eliminates fretting corrosion and is unaffected by alternating torques
- Angular and axial misalignment capability

Taper Bushes

Range and Material Specifications:

Challenge Taper Bushes are manufactured to the highest quality standards using GG22 - 25 cast iron depending on size. Thin wall bushes are produced either from C45 steel or GGG close grain cast iron. All surfaces are carefully machined to provide maximum contact area and transmission of torque.

In excess of 700 sizes of Challenge Taper Bushes are manufactured and stocked making this one of the most comprehensive ranges available today.

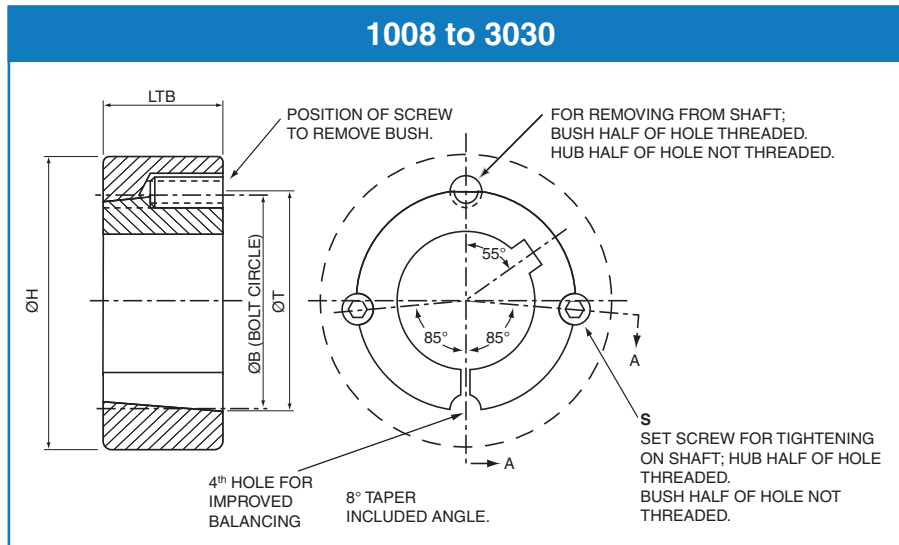

Taper Bush 1008 to 3030

Bush Size	T	LTB	Minimum hub Dia H			B	Set Screws S	
			200 N/mm ² GG Iron	250 N/mm ² GG Iron	420 N/mm ² Steel		Quantity	Size (BSW)
1008	35.20	22.3	59	54	51	33.73	2	1/4" x 1/2"
1108	38.38	22.3	61	57	54	36.92	2	1/4" x 1/2"
1210	47.62	25.4	99	86	78	44.44	2	3/8" x 5/8"
1215	47.62	38.1	79	73	68	44.44	2	3/8" x 5/8"
1310	50.80	25.4	100	88	80	47.63	2	3/8" x 5/8"
1610	57.15	25.4	102	92	85	53.97	2	3/8" x 5/8"
1615	57.15	38.1	86	81	77	53.97	2	3/8" x 5/8"
2012	69.85	31.8	115	106	99	66.68	2	7/16" x 7/8"
2517	85.73	44.5	125	119	113	82.55	2	1/2" x 1"
2525	85.73	63.5	115	111	108	82.56	2	1/2" x 1"
3020	107.96	50.8	154	146	140	101.60	2	5/8" x 1.1/4"
3030	107.96	76.2	141	136	132	101.60	2	5/8" x 1.1/4"

Severe operating conditions may require the use of a larger diameter hub.

Taper Bushes

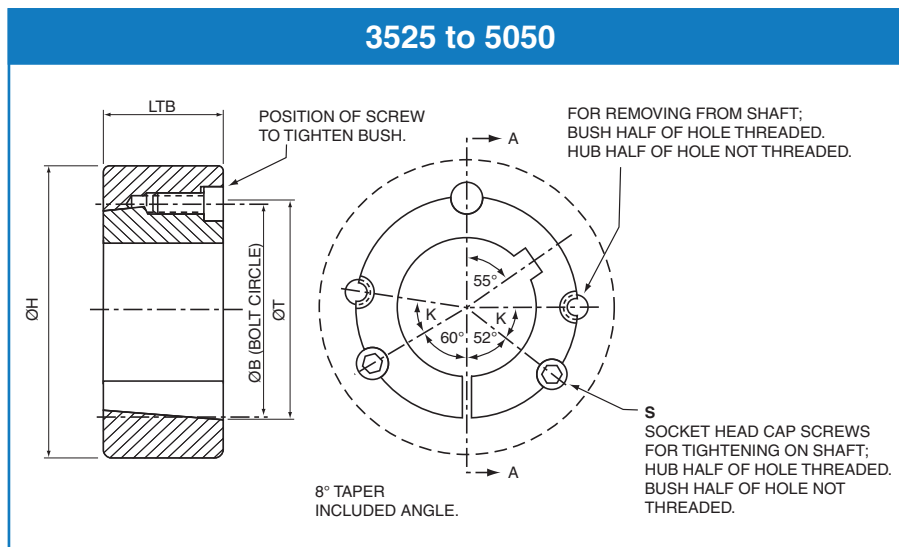

Taper Bush 3525 to 5050

Bush Size	T	LTB	Minimum hub Dia H			B	Cap Screws S		K
			200 N/mm ² GG Iron	250 N/mm ² GG Iron	420 N/mm ² Steel		Quantity	Size (BSW)	
3525	127.00	63.5	206	191	178	122.68	3	1/2" x 1.1/2"	40°
3535	127.00	89.0	185	176	168	122.68	3	1/2" x 1.1/2"	40°
4030	146.05	76.2	220	207	197	140.72	3	5/8" x 1.3/4"	40°
4040	146.05	101.5	203	195	188	140.72	3	5/8" x 1.1/4"	40°
4535	161.93	89.0	221	212	205	155.70	3	3/4" x 2"	40°
4545	161.93	114.3	211	205	200	155.70	3	3/4" x 2"	40°
5040	177.80	101.6	236	229	223	170.69	3	7/8" x 2.1/4"	37°
5050	177.80	127.0	230	223	219	170.69	3	7/8" x 2.1/4"	37°

Severe operating conditions may require the use of a larger diameter hub.

Taper Bushes

To Install

- 1 Ensure the mating surfaces are clean and free from oil and dirt. Insert the bush into the hub so that the securing holes are aligned
- 2 Lightly oil the thread of the screws and place them loosely into the threaded holes of the hub as shown in the diagram
- 3 Clean the shaft and fit the hub and bush to the shaft as one unit in the desired position. Remember that the bush will nip the shaft first and the hub will then be drawn slightly on to the bush
- 4 Using a hexagon wrench, gradually tighten the screws alternately until tight
- 5 Hammer against the large end of the bush using a block to avoid damaging the bush. The screws can now be tightened more. Repeat this procedure until the correct wrench tightening torque is achieved from the table below
- 6 To achieve the best balance, if a key is not used, position the keyways in the bush and hub diametrically opposite to each other
- 7 If a key is to be fitted, locate it in the shaft keyway before fitting the bush. It is essential that a parallel key with top clearance be fitted. Under no circumstances should taper or top fitting keys be used
- 8 After the drive has been running for a short time, check the tightness of the screws
- 9 Finally, fill all empty holes with grease to exclude dirt and prevent corrosion

To Remove

- 1 Slacken all screws and remove one or two screws, according to the number of removal holes (see diagrams)
- 2 Lightly oil the screw(s) and insert it or them into the removal hole(s) and tighten down until the assembly loosens. If the bush does not loosen immediately, lightly tap the hub
- 3 Remove the assembly from the shaft

1008 to 3030

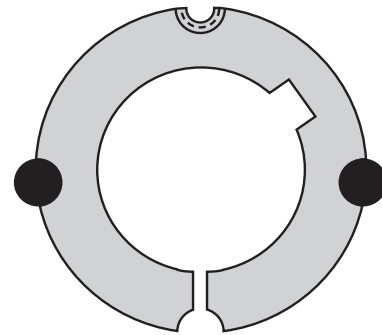

3525 to 5050

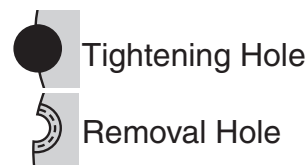
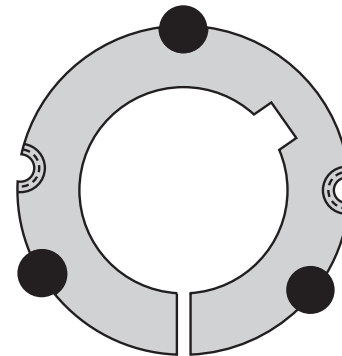

Recommended Wrench Torque

Bush Size	Screws	Tightening Torque (Nm)	Bush Size	Screws	Tightening Torque (Nm)	Bush Size	Screws	Tightening Torque (Nm)
1008	1/4" Set Screws	6	2012	7/16" Set Screws	30	4030	5/8" Cap Screws	170
1108	1/4" Set Screws	6	2517	1/2" Set Screws	50	4040	5/8" Cap Screws	170
1210	3/8" Set Screws	20	2525	1/2" Set Screws	50	4535	3/4" Cap Screws	190
1215	3/8" Set Screws	20	3020	5/8" Set Screws	90	4545	3/4" Cap Screws	190
1310	3/8" Set Screws	20	3030	5/8" Set Screws	90	5040	7/8" Cap Screws	270
1610	3/8" Set Screws	20	3525	1/2" Cap Screws	105	5050	7/8" Cap Screws	270
1615	3/8" Set Screws	20	3535	1/2" Cap Screws	105			

All dimensions in millimetres unless otherwise stated. Every effort has been taken to ensure that the data listed in this catalogue is correct. Challenge accepts no liability for any inaccuracies or damage caused.

Taper Bushes - Metric

1008

Bore	Weight kg †	Keyseat	
		Bush	Shaft
9	0.13	3 x 1.4	3 x 1.8
10	0.13	3 x 1.4	3 x 1.8
11	0.12	4 x 1.8	4 x 2.5
12	0.12	4 x 1.8	4 x 2.5
14	0.11	5 x 2.3	5 x 3.0
15	0.11	5 x 2.3	5 x 3.0
16	0.10	5 x 2.3	5 x 3.0
18	0.10	6 x 2.8	6 x 3.5
19	0.09	6 x 2.8	6 x 3.5
20	0.09	6 x 2.8	6 x 3.5
22	0.08	6 x 2.8	6 x 3.5
24*	0.07	8 x 1.3*	8 x 4.0
25*	0.06	8 x 1.3*	8 x 4.0

1108

Bore	Weight kg †	Keyseat	
		Bush	Shaft
9	0.15	3 x 1.4	3 x 1.8
10	0.15	3 x 1.4	3 x 1.8
11	0.15	4 x 1.8	4 x 2.5
12	0.14	4 x 1.8	4 x 2.5
14	0.14	5 x 2.3	5 x 3.0
15	0.13	5 x 2.3	5 x 3.0
16	0.13	5 x 2.3	5 x 3.0
17	0.12	5 x 2.3	5 x 3.0
18	0.12	6 x 2.8	6 x 3.5
19	0.11	6 x 2.8	6 x 3.5
20	0.11	6 x 2.8	6 x 3.5
22	0.10	6 x 2.8	6 x 3.5
24	0.09	8 x 3.3	8 x 4.0
25	0.08	8 x 3.3	8 x 4.0
28*	0.06	8 x 1.3*	8 x 4.0

1210

Bore	Weight kg †	Keyseat	
		Bush	Shaft
11	0.26	4 x 1.8	4 x 2.5
12	0.26	4 x 1.8	4 x 2.5
14	0.25	5 x 2.3	5 x 3.0
15	0.25	5 x 2.3	5 x 3.0
16	0.24	5 x 2.3	5 x 3.0
18	0.23	6 x 2.8	6 x 3.5
19	0.23	6 x 2.8	6 x 3.5
20	0.22	6 x 2.8	6 x 3.5
22	0.21	6 x 2.8	6 x 3.5
24	0.19	8 x 3.3	8 x 4.0
25	0.19	8 x 3.3	8 x 4.0
28	0.16	8 x 3.3	8 x 4.0
30	0.15	8 x 3.3	8 x 4.0
32	0.14	10 x 3.3	10 x 5.0

1215

Bore	Weight kg †	Keyseat	
		Bush	Shaft
11	0.39	4 x 1.8	4 x 2.5
12	0.39	4 x 1.8	4 x 2.5
14	0.37	5 x 2.3	5 x 3.0
16	0.36	5 x 2.3	5 x 3.0
18	0.34	6 x 2.8	6 x 3.5
19	0.34	6 x 2.8	6 x 3.5
20	0.33	6 x 2.8	6 x 3.5
22	0.31	6 x 2.8	6 x 3.5
24	0.29	8 x 3.3	8 x 4.0
25	0.28	8 x 3.3	8 x 4.0
28	0.24	8 x 3.3	8 x 4.0
30	0.22	8 x 3.3	8 x 4.0
32	0.20	10 x 3.3	10 x 5.0

1310

Bore	Weight kg †	Keyseat	
		Bush	Shaft
14	0.31	5 x 2.3	5 x 3.0
16	0.30	5 x 2.3	5 x 3.0
18	0.29	6 x 2.8	6 x 3.5
19	0.28	6 x 2.8	6 x 3.5
20	0.28	6 x 2.8	6 x 3.5
22	0.26	5 x 2.8	6 x 3.5
24	0.25	8 x 3.3	8 x 4.0
25	0.25	8 x 3.3	8 x 4.0
28	0.22	8 x 3.3	8 x 4.0
30	0.20	8 x 3.3	8 x 4.0
32	0.18	10 x 3.3	10 x 5.0
35	0.16	10 x 3.3	10 x 5.0

1610

Bore	Weight kg †	Keyseat	
		Bush	Shaft
14	0.38	5 x 2.3	5 x 3.0
15	0.37	5 x 2.3	5 x 3.0
16	0.37	5 x 2.3	5 x 3.0
18	0.36	6 x 2.8	6 x 3.5
19	0.35	6 x 2.8	6 x 3.5
20	0.35	6 x 2.8	6 x 3.5
22	0.33	6 x 2.8	6 x 3.5
24	0.32	8 x 3.3	8 x 4.0
25	0.31	8 x 3.3	8 x 4.0
28	0.29	8 x 3.3	8 x 4.0
30	0.27	8 x 3.3	8 x 4.0
32	0.26	10 x 3.3	10 x 5.0
35	0.22	10 x 3.3	10 x 5.0
38	0.19	10 x 3.3	10 x 5.0
40	0.18	12 x 3.3	12 x 5.0
42	0.16	12 x 3.3	12 x 5.0

† Net weight including screws.

Bold italic type indicates bushes made of **steel**.

Keyways are in accordance with BS4235, Part 1, 1972, DIN6885 and conform to ISO recommendations with the exception of those marked* which are shallower.

Depth of key measured at centre.

Every effort has been taken to ensure that the data listed in this catalogue is correct. Challenge accepts no liability for any inaccuracies or damage caused. All dimensions in millimetres unless otherwise stated.

Taper Bushes - Metric

1615

Bore	Weight kg †	Keyseat	
		Bush	Shaft
14	0.57	5 x 2.3	5 x 3.0
16	0.56	5 x 2.3	5 x 3.0
18	0.54	6 x 2.8	6 x 3.5
19	0.54	6 x 2.8	6 x 3.5
20	0.53	6 x 2.8	6 x 3.5
22	0.51	6 x 2.8	6 x 3.5
24	0.49	8 x 3.3	6 x 4.0
25	0.48	8 x 3.3	8 x 4.0
28	0.44	8 x 3.3	8 x 4.0
30	0.42	8 x 3.3	8 x 4.0
32	0.39	10 x 3.3	10 x 5.0
35	0.34	10 x 3.3	10 x 5.0
38	0.30	10 x 3.3	10 x 5.0
40	0.28	12 x 3.3	12 x 5.0
42*	0.24	12 x 2.2*	12 x 5.0

2517

Bore	Weight kg †	Keyseat	
		Bush	Shaft
16	1.67	5 x 2.3	5 x 3.0
18	1.65	6 x 2.8	6 x 3.5
19	1.64	6 x 2.8	6 x 3.5
20	1.63	6 x 2.8	6 x 3.5
22	1.61	6 x 2.8	6 x 3.5
24	1.59	8 x 3.3	8 x 4.0
25	1.57	8 x 3.3	8 x 4.0
28	1.53	8 x 3.3	8 x 4.0
30	1.50	8 x 3.3	8 x 4.0
32	1.47	10 x 3.3	10 x 5.0
35	1.42	10 x 3.3	10 x 5.0
38	1.36	10 x 3.3	10 x 5.0
40	1.32	12 x 3.3	12 x 5.0
42	1.28	12 x 3.3	12 x 5.0
45	1.21	14 x 3.8	14 x 5.5
48	1.14	14 x 3.8	14 x 5.5
50	1.09	14 x 3.8	14 x 5.5
55	0.96	16 x 4.3	16 x 6.0
60	0.81	18 x 4.4	18 x 7.0
65	0.65	18 x 4.4	18 x 7.0

3020

Bore	Weight kg †	Keyseat	
		Bush	Shaft
20	2.93	8 x 3.3	8 x 4.0
25	2.87	8 x 3.3	8 x 4.0
28	2.82	8 x 3.3	8 x 4.0
30	2.79	8 x 3.3	8 x 4.0
32	2.75	10 x 3.3	10 x 5.0
35	2.69	10 x 3.3	10 x 5.0
38	2.63	10 x 3.3	10 x 5.0
40	2.58	12 x 3.3	12 x 5.0
42	2.53	12 x 3.3	12 x 5.0
45	2.46	14 x 3.8	14 x 5.5
48	2.37	14 x 3.8	14 x 5.5
50	2.32	14 x 3.8	14 x 5.5
55	2.16	16 x 4.3	16 x 6.0
60	1.99	18 x 4.4	18 x 7.0
65	1.81	18 x 4.4	18 x 7.0
70	1.61	20 x 4.9	20 x 7.5
75	1.39	20 x 4.9	20 x 7.5

2012

Bore	Weight kg †	Keyseat	
		Bush	Shaft
14	0.76	5 x 2.3	5 x 3.0
16	0.75	5 x 2.3	5 x 3.0
18	0.74	6 x 2.8	6 x 3.5
19	0.73	6 x 2.8	6 x 3.5
20	0.73	6 x 2.8	6 x 3.5
22	0.71	6 x 2.8	6 x 3.5
24	0.69	8 x 3.3	8 x 4.0
25	0.69	8 x 3.3	8 x 4.0
28	0.66	8 x 3.3	8 x 4.0
30	0.63	8 x 3.3	8 x 4.0
32	0.61	10 x 3.3	10 x 5.0
35	0.57	10 x 3.3	10 x 5.0
38	0.53	10 x 3.3	10 x 5.0
40	0.51	12 x 3.3	12 x 5.0
42	0.48	12 x 3.3	12 x 5.0
45	0.43	14 x 3.8	14 x 5.5
48	0.38	14 x 3.8	14 x 5.5
50	0.34	14 x 3.8	14 x 5.5

2525

Bore	Weight kg †	Keyseat	
		Bush	Shaft
18	2.18	6 x 2.8	6 x 3.5
19	2.17	6 x 2.8	6 x 3.5
20	2.16	6 x 2.8	6 x 3.5
22	2.13	6 x 2.8	6 x 3.5
24	2.09	8 x 3.3	8 x 4.0
25	2.07	8 x 3.3	8 x 4.0
28	2.02	8 x 3.3	8 x 4.0
30	1.97	8 x 3.3	8 x 4.0
32	1.93	10 x 3.3	10 x 5.0
35	1.85	10 x 3.3	10 x 5.0
38	1.77	10 x 3.3	10 x 5.0
40	1.71	12 x 3.3	12 x 5.0
42	1.65	12 x 3.3	12 x 5.0
45	1.56	14 x 3.8	14 x 5.5
48	1.46	14 x 3.8	14 x 5.5
50	1.38	14 x 3.8	14 x 5.5
55	1.19	16 x 4.3	16 x 6.0
60	0.98	18 x 4.4	18 x 7.0

3030

Bore	Weight kg †	Keyseat	
		Bush	Shaft
25	4.04	8 x 3.3	8 x 4.0
35	3.77	10 x 3.3	10 x 5.0
38	3.67	10 x 3.3	10 x 5.0
40	3.60	12 x 3.3	12 x 5.0
42	3.53	12 x 3.3	12 x 5.0
45	3.42	14 x 3.8	14 x 5.5
48	3.29	14 x 3.8	14 x 5.5
50	3.21	14 x 3.8	14 x 5.5
55	2.98	16 x 4.3	16 x 6.0
60	2.72	18 x 4.4	18 x 7.0
65	2.44	18 x 4.4	18 x 7.0
70	2.15	20 x 4.9	20 x 7.5
75	1.83	20 x 4.9	20 x 7.5

† Net weight including screws.

Bold italic type indicates bushes made of **steel**.

Keyways are in accordance with BS4235, Part 1, 1972, DIN6885 and conform to ISO recommendations with the exception of those marked* which are shallower.

Depth of key measured at centre.

Taper Bushes - Metric

3525

Bore	Weight kg †	Keyseat	
		Bush	Shaft
35	4.91	10 x 3.3	10 x 5.0
38	4.83	10 x 3.3	10 x 5.0
40	4.77	12 x 3.3	12 x 5.0
42	4.71	12 x 3.3	12 x 5.0
45	4.62	14 x 3.8	14 x 5.5
48	4.52	14 x 3.8	14 x 5.5
50	4.44	14 x 3.8	14 x 5.5
55	4.25	16 x 4.3	16 x 6.0
60	4.04	18 x 4.4	18 x 7.0
65	3.81	18 x 4.4	18 x 7.0
70	3.56	20 x 4.9	20 x 7.5
75	3.29	20 x 4.9	20 x 7.5
80	3.01	22 x 5.4	22 x 9.0
85	2.70	22 x 5.4	22 x 9.0
90	2.38	25 x 5.4	25 x 9.0
95	2.17	25 x 5.4	25 x 9.0
100*	1.79	28 x 5.4*	28 x 10.0

3535

Bore	Weight kg †	Keyseat	
		Bush	Shaft
32	6.65	10 x 3.3	10 x 5.0
35	6.55	10 x 3.3	10 x 5.0
38	6.43	10 x 3.3	10 x 5.0
40	6.35	12 x 3.3	12 x 5.0
42	6.27	12 x 3.3	12 x 5.0
45	6.13	14 x 3.8	14 x 5.5
48	5.99	14 x 3.8	14 x 5.5
50	5.89	14 x 3.8	14 x 5.5
55	5.62	16 x 4.3	16 x 6.0
60	5.32	18 x 4.4	18 x 7.0
65	5.00	18 x 4.4	18 x 7.0
70	4.65	20 x 4.9	20 x 7.5
75	4.28	20 x 4.9	20 x 7.5
80	3.88	22 x 5.4	22 x 9.0
85	3.45	22 x 5.4	22 x 9.0
90	3.00	25 x 5.4	25 x 9.0

4030

Bore	Weight kg †	Keyseat	
		Bush	Shaft
40	7.55	12 x 3.3	12 x 5.0
42	7.48	12 x 3.3	12 x 5.0
45	7.36	14 x 3.8	14 x 5.5
48	7.24	14 x 3.8	14 x 5.5
50	7.15	14 x 3.8	14 x 5.5
55	6.92	16 x 4.3	16 x 6.0
60	6.67	18 x 4.4	18 x 7.0
65	6.39	18 x 4.4	18 x 7.0
70	6.09	20 x 4.9	20 x 7.5
75	5.77	20 x 4.9	20 x 7.5
80	5.43	22 x 5.4	22 x 9.0
85	5.06	22 x 5.4	22 x 9.0
90	4.68	25 x 5.4	25 x 9.0
95	4.27	25 x 5.4	25 x 9.0
100	3.84	28 x 6.4	28 x 10.0
105	3.59	28 x 6.4	28 x 10.0
110	3.09	28 x 6.4	28 x 10.0
115*	2.56	32 x 5.4*	32 x 11.0

4040

Bore	Weight kg †	Keyseat	
		Bush	Shaft
40	9.83	12 x 3.3	12 x 5.0
42	9.73	12 x 3.3	12 x 5.0
45	9.58	14 x 3.8	14 x 5.5
48	9.41	14 x 3.8	14 x 5.5
50	9.30	14 x 3.8	14 x 5.5
55	8.99	16 x 4.3	16 x 6.0
60	8.65	18 x 4.4	18 x 7.0
65	8.28	18 x 4.4	18 x 7.0
70	7.88	20 x 4.9	20 x 7.5
75	7.46	20 x 4.9	20 x 7.5
80	7.00	22 x 5.4	22 x 9.0
85	6.51	22 x 5.4	22 x 9.0
90	6.00	25 x 5.4	25 x 9.0
95	5.45	25 x 5.4	25 x 9.0
100	4.88	28 x 6.4	28 x 10.0

† Net weight including screws.

Bold italic type indicates bushes made of **GGG cast iron**.

Keyways are in accordance with BS4235, Part 1, 1972, DIN6885 and conform to ISO recommendations with the exception of those marked* which are shallower.

Depth of key measured at centre.

Taper Bushes - Metric

4535

Bore	Weight kg †	Keyseat	
		Bush	Shaft
55	10.33	16 x 4.3	10 x 6.0
60	10.03	18 x 4.4	18 x 7.0
65	9.71	18 x 4.4	18 x 7.0
70	9.36	20 x 4.9	20 x 7.5
75	8.99	20 x 4.9	20 x 7.5
80	8.59	22 x 5.4	22 x 9.0
85	8.16	22 x 5.4	22 x 9.0
90	7.71	25 x 5.4	25 x 9.0
95	7.23	25 x 5.4	25 x 9.0
100	6.73	28 x 6.4	28 x 10.0
105	6.20	28 x 6.4	28 x 10.0
110	5.65	28 x 6.4	28 x 10.0
115	5.38	32 x 7.4	32 x 11.0
120	4.73	32 x 7.4	32 x 11.0
125	4.06	32 x 7.4	32 x 11.0

4545

Bore	Weight kg †	Keyseat	
		Bush	Shaft
55	13.72	16 x 4.3	16 x 6.0
60	13.34	18 x 4.4	18 x 7.0
65	12.93	18 x 4.4	18 x 7.0
70	12.48	20 x 4.9	20 x 7.5
75	12.00	20 x 4.9	20 x 7.5
80	11.49	22 x 5.4	22 x 9.0
85	10.94	22 x 5.4	22 x 9.0
90	10.36	25 x 5.4	25 x 9.0
95	9.75	25 x 5.4	25 x 9.0
100	9.10	28 x 6.4	28 x 10.0
105	8.42	28 x 6.4	28 x 10.0
110	7.71	28 x 6.4	28 x 10.0

5040

Bore	Weight kg †	Keyseat	
		Bush	Shaft
70	13.42	20 x 4.9	20 x 7.5
75	12.99	20 x 4.9	20 x 7.5
80	12.53	22 x 5.4	22 x 9.0
85	12.05	22 x 5.4	22 x 9.0
90	11.53	25 x 5.4	25 x 9.0
95	10.99	25 x 5.4	25 x 9.0
100	10.41	28 x 6.4	28 x 10.0
105	9.81	28 x 6.4	28 x 10.0
110	9.17	28 x 6.4	28 x 10.0
115	8.51	32 x 7.4	32 x 11.0
120	7.82	32 x 7.4	32 x 11.0
125	7.10	32 x 7.4	32 x 11.0

5050

Bore	Weight kg †	Keyseat	
		Bush	Shaft
70	16.33	20 x 4.9	20 x 7.5
75	15.80	20 x 4.9	20 x 7.5
80	15.23	22 x 5.4	22 x 9.0
85	14.62	22 x 5.4	22 x 9.0
90	13.97	25 x 5.4	25 x 9.0
95	13.29	25 x 5.4	25 x 9.0
100	12.58	28 x 6.4	28 x 10.0
105	11.82	28 x 6.4	28 x 10.0
110	11.03	28 x 6.4	28 x 10.0
115	10.20	32 x 7.4	32 x 11.0
120	9.33	32 x 7.4	32 x 11.0
125	8.43	32 x 7.4	32 x 11.0

† Net weight including screws.

Bold italic type indicates bushes made of **GGG cast iron**.

Keyways are in accordance with BS4235, Part 1, 1972, DIN6885 and conform to ISO recommendations with the exception of those marked* which are shallower.

Depth of key measured at centre.

NOTE

CHALLENGE can manufacture larger taper bush sizes including 6050, 7060 and 8065. These are available to order with the following maximum bores:

6050 150 mm or 6"

7060 175 mm or 7"

8065 200 mm or 8"

Pilot bore taper bushes in these sizes are also available.

Taper Bushes - Imperial

1008

Bore	Weight		Keyseat	
	kg †	Bush	Shaft	
3/8	0.13	0.125 x 0.060	0.125 x 0.072	
7/16	0.12	0.125 x 0.060	0.125 x 0.072	
1/2	0.12	0.125 x 0.060	0.125 x 0.072	
9/16	0.11	0.125 x 0.060	0.125 x 0.072	
5/8	0.11	0.188 x 0.088	0.188 x 0.107	
11/16	0.10	0.188 x 0.088	0.188 x 0.107	
3/4	0.09	0.188 x 0.088	0.188 x 0.107	
13/16	0.09	0.250 x 0.115	0.250 x 0.142	
7/8	0.08	0.250 x 0.115	0.250 x 0.142	
15/16	0.07	0.250 x 0.115	0.250 x 0.142	
1*	0.06	0.250 x 0.052*	0.250 x 0.142	

1108

Bore	Weight		Keyseat	
	kg †	Bush	Shaft	
3/8	0.15	0.125 x 0.060	0.125 x 0.072	
7/16	0.14	0.125 x 0.060	0.125 x 0.072	
1/2	0.14	0.125 x 0.060	0.125 x 0.072	
9/16	0.13	0.188 x 0.088	0.188 x 0.107	
5/8	0.13	0.188 x 0.088	0.188 x 0.107	
11/16	0.12	0.188 x 0.088	0.188 x 0.107	
3/4	0.11	0.188 x 0.088	0.188 x 0.107	
13/16	0.11	0.250 x 0.115	0.250 x 0.142	
7/8	0.10	0.250 x 0.115	0.250 x 0.142	
15/16	0.09	0.250 x 0.115	0.250 x 0.142	
1	0.08	0.250 x 0.115	0.250 x 0.142	
1.1/16	0.07	0.312 x 0.065*	0.312 x 0.177	
1.1/8*	0.06	0.312 x 0.065*	0.312 x 0.177	

1210

Bore	Weight		Keyseat	
	kg †	Bush	Shaft	
1/2	0.25	0.125 x 0.060	0.125 x 0.072	
9/16	0.24	0.188 x 0.088	0.188 x 0.107	
5/8	0.24	0.188 x 0.088	0.188 x 0.107	
11/16	0.23	0.188 x 0.088	0.188 x 0.107	
3/4	0.22	0.188 x 0.088	0.188 x 0.107	
13/16	0.21	0.250 x 0.115	0.250 x 0.142	
7/8	0.20	0.250 x 0.115	0.250 x 0.142	
15/16	0.19	0.250 x 0.115	0.250 x 0.142	
1	0.18	0.250 x 0.115	0.250 x 0.142	
1.1/16	0.17	0.312 x 0.112	0.312 x 0.177	
1.1/8	0.15	0.312 x 0.112	0.312 x 0.177	
1.3/16	0.14	0.312 x 0.112	0.312 x 0.177	
1.1/4	0.13	0.312 x 0.112	0.312 x 0.177	
1.5/16	0.12	0.375 x 0.112	0.375 x 0.213	

1215

Bore	Weight		Keyseat	
	kg †	Bush	Shaft	
9/16	0.38	0.188 x 0.088	0.188 x 0.101	
5/8	0.36	0.188 x 0.088	0.188 x 0.101	
11/16	0.34	0.188 x 0.088	0.188 x 0.107	
3/4	0.33	0.188 x 0.088	0.188 x 0.107	
13/16	0.32	0.250 x 0.115	0.250 x 0.142	
7/8	0.30	0.250 x 0.115	0.250 x 0.142	
15/16	0.28	0.250 x 0.115	0.250 x 0.142	
1	0.27	0.250 x 0.115	0.250 x 0.142	
1.1/16	0.25	0.312 x 0.112	0.312 x 0.177	
1.1/8	0.23	0.312 x 0.112	0.312 x 0.177	
1.3/16	0.21	0.312 x 0.112	0.312 x 0.177	
1.1/4	0.20	0.312 x 0.112	0.312 x 0.177	

1310

Bore	Weight		Keyseat	
	kg †	Bush	Shaft	
1/2	0.31	0.125 x 0.060	0.125 x 0.072	
5/8	0.30	0.188 x 0.088	0.188 x 0.107	
3/4	0.28	0.188 x 0.088	0.188 x 0.107	
7/8	0.26	0.250 x 0.115	0.250 x 0.142	
1	0.24	0.250 x 0.115	0.250 x 0.142	
1.1/8	0.21	0.312 x 0.112	0.312 x 0.177	
1.1/4	0.19	0.312 x 0.112	0.312 x 0.177	
1.3/8	0.16	0.375 x 0.110	0.375 x 0.213	

1610

Bore	Weight		Keyseat	
	kg †	Bush	Shaft	
1/2	0.38	0.125 x 0.060	0.125 x 0.072	
9/16	0.37	0.188 x 0.088	0.188 x 0.107	
5/8	0.37	0.188 x 0.088	0.188 x 0.107	
11/16	0.36	0.188 x 0.088	0.188 x 0.107	
3/4	0.35	0.188 x 0.088	0.188 x 0.107	
13/16	0.34	0.250 x 0.115	0.250 x 0.142	
7/8	0.33	0.250 x 0.115	0.250 x 0.142	
15/16	0.32	0.250 x 0.115	0.250 x 0.142	
1	0.31	0.250 x 0.115	0.250 x 0.142	
1.1/16	0.30	0.312 x 0.112	0.312 x 0.177	
1.1/8	0.28	0.312 x 0.112	0.312 x 0.177	
1.3/16	0.27	0.312 x 0.112	0.312 x 0.177	
1.1/4	0.26	0.312 x 0.112	0.312 x 0.177	
1.5/16	0.24	0.375 x 0.110	0.375 x 0.213	
1.3/8	0.22	0.375 x 0.110	0.375 x 0.213	
1.7/16	0.21	0.375 x 0.110	0.375 x 0.213	
1.1/2	0.19	0.375 x 0.110	0.375 x 0.213	
1.9/16	0.17	0.438 x 0.134	0.438 x 0.248	
1.5/8	0.16	0.438 x 0.134	0.438 x 0.248	
1.11/16	0.15	0.438 x 0.134	0.438 x 0.248	

† Net weight including screws.

Bold italic type indicates bushes made of steel.

Keyways are parallel and in accordance with BS46: Part 1:1958, with the exception of those marked* which are shallower.

Depth of key measured at centre

All dimensions are in inches

Every effort has been taken to ensure that the data listed in this catalogue is correct. Challenge accepts no liability for any inaccuracies or damage caused.

Taper Bushes - Imperial

1615

Bore	Weight		Keyseat	
	kg †	Bush	Shaft	
1/2	0.58	0.125 x 0.060	0.125 x 0.072	
5/8	0.56	0.188 x 0.088	0.188 x 0.107	
3/4	0.54	0.188 x 0.088	0.188 x 0.107	
7/8	0.51	0.250 x 0.115	0.250 x 0.142	
1	0.48	0.250 x 0.115	0.250 x 0.142	
1.1/8	0.44	0.312 x 0.112	0.312 x 0.177	
1.1/4	0.40	0.312 x 0.112	0.312 x 0.177	
1.5/16	0.37	0.375 x 0.110	0.375 x 0.213	
1.3/8	0.35	0.375 x 0.110	0.375 x 0.213	
1.7/16	0.32	0.375 x 0.110	0.375 x 0.213	
1.1/2	0.30	0.375 x 0.110	0.375 x 0.213	
1.5/8*	0.26	0.438 x 0.103*	0.438 x 0.248	

2012

Bore	Weight		Keyseat	
	kg †	Bush	Shaft	
7/16	0.79	0.125 x 0.060	0.125 x 0.072	
9/16	0.77	0.188 x 0.088	0.188 x 0.107	
5/8	0.76	0.188 x 0.088	0.188 x 0.107	
11/16	0.75	0.188 x 0.088	0.188 x 0.107	
3/4	0.74	0.188 x 0.088	0.188 x 0.107	
13/16	0.72	0.250 x 0.115	0.250 x 0.142	
7/8	0.71	0.250 x 0.115	0.250 x 0.142	
15/16	0.70	0.250 x 0.115	0.250 x 0.142	
1	0.69	0.250 x 0.115	0.250 x 0.142	
1.1/16	0.67	0.312 x 0.112	0.312 x 0.177	
1.1/8	0.65	0.312 x 0.112	0.312 x 0.177	
1.3/16	0.64	0.312 x 0.112	0.312 x 0.177	
1.1/4	0.62	0.312 x 0.112	0.312 x 0.177	
1.5/16	0.60	0.375 x 0.110	0.375 x 0.213	
1.3/8	0.58	0.375 x 0.110	0.375 x 0.213	
1.7/16	0.56	0.375 x 0.110	0.375 x 0.213	
1.1/2	0.54	0.375 x 0.110	0.375 x 0.213	
1.9/16	0.52	0.438 x 0.134	0.438 x 0.248	
1.5/8	0.49	0.438 x 0.134	0.438 x 0.248	
1.11/16	0.47	0.438 x 0.134	0.438 x 0.248	
1.3/4	0.44	0.438 x 0.134	0.438 x 0.248	
1.13/16	0.42	0.500 x 0.131	0.500 x 0.283	
1.7/8	0.39	0.500 x 0.131	0.500 x 0.283	
1.15/16	0.36	0.500 x 0.131	0.500 x 0.283	
2	0.35	0.500 x 0.131	0.500 x 0.283	

2517

Bore	Weight		Keyseat	
	kg †	Bush	Shaft	
3/4	1.64	0.188 x 0.088	0.188 x 0.107	
13/16	1.62	0.250 x 0.115	0.250 x 0.142	
7/8	1.61	0.250 x 0.115	0.250 x 0.142	
15/16	1.59	0.250 x 0.115	0.250 x 0.142	
1	1.57	0.250 x 0.115	0.250 x 0.142	
1.1/16	1.55	0.312 x 0.112	0.312 x 0.177	
1.1/8	1.53	0.312 x 0.112	0.312 x 0.177	
1.3/16	1.51	0.312 x 0.112	0.312 x 0.177	
1.1/4	1.48	0.312 x 0.112	0.312 x 0.177	
1.5/16	1.45	0.375 x 0.110	0.375 x 0.213	
1.3/8	1.42	0.375 x 0.110	0.375 x 0.213	
1.7/16	1.39	0.375 x 0.110	0.375 x 0.213	
1.1/2	1.36	0.375 x 0.110	0.375 x 0.213	
1.9/16	1.33	0.438 x 0.134	0.438 x 0.248	
1.5/8	1.30	0.438 x 0.134	0.438 x 0.248	
1.11/16	1.26	0.438 x 0.134	0.438 x 0.248	
1.3/4	1.23	0.438 x 0.134	0.438 x 0.248	
1.13/16	1.19	0.500 x 0.131	0.500 x 0.263	
1.7/8	1.15	0.500 x 0.131	0.500 x 0.263	
1.15/16	1.11	0.500 x 0.131	0.500 x 0.263	
2	1.07	0.500 x 0.131	0.500 x 0.283	
2.1/8	0.99	0.625 x 0.185	0.625 x 0.354	
2.3/16	0.94	0.625 x 0.185	0.625 x 0.354	
2.1/4	0.90	0.625 x 0.185	0.625 x 0.354	
2.5/16	0.85	0.625 x 0.185	0.625 x 0.354	
2.3/8	0.80	0.625 x 0.185	0.625 x 0.354	
2.7/16	0.75	0.625 x 0.185	0.625 x 0.354	
2.1/2	0.70	0.625 x 0.185	0.625 x 0.354	

2525

Bore	Weight		Keyseat	
	kg †	Bush	Shaft	
7/8	2.12	0.250 x 0.115	0.250 x 0.142	
1	2.07	0.250 x 0.115	0.250 x 0.142	
1.1/8	2.01	0.312 x 0.112	0.312 x 0.177	
1.1/4	1.93	0.312 x 0.112	0.312 x 0.177	
1.3/8	1.86	0.375 x 0.110	0.375 x 0.213	
1.1/2	1.77	0.375 x 0.110	0.375 x 0.213	
1.5/8	1.68	0.438 x 0.134	0.438 x 0.248	
1.3/4	1.58	0.438 x 0.134	0.438 x 0.248	
1.7/8	1.47	0.500 x 0.131	0.500 x 0.283	
2	1.36	0.500 x 0.131	0.500 x 0.283	
2.1/8	1.23	0.625 x 0.185	0.625 x 0.364	
2.1/4	1.10	0.625 x 0.185	0.625 x 0.354	
2.3/8	0.97	0.625 x 0.185	0.625 x 0.354	
2.1/2	0.82	0.625 x 0.153*	0.625 x 0.354	

† Net weight including screws.

Bold italic type indicates bushes made of **steel**.

Keyways are parallel and in accordance with BS46: Part 1:1958, with the exception of those marked* which are shallower.

Depth of key measured at centre

All dimensions are in inches

Every effort has been taken to ensure that the data listed in this catalogue is correct. Challenge accepts no liability for any inaccuracies or damage caused.

Taper Bushes - Imperial

3020

Bore	Weight	Keyseat	
	kg †	Bush	Shaft
1.1/16	2.85	0.312 x 0.112	0.212 x 0.177
1.3/16	2.80	0.312 x 0.112	0.212 x 0.177
1.1/4	2.75	0.312 x 0.112	0.212 x 0.177
1.5/16	2.72	0.375 x 0.110	0.375 x 0.213
1.3/8	2.69	0.375 x 0.110	0.375 x 0.213
1.7/16	2.65	0.375 x 0.110	0.375 x 0.213
1.1/2	2.62	0.375 x 0.110	0.375 x 0.213
1.9/16	2.59	0.438 x 0.134	0.438 x 0.248
1.5/8	2.55	0.438 x 0.134	0.438 x 0.248
1.11/16	2.51	0.438 x 0.134	0.438 x 0.248
1.3/4	2.47	0.438 x 0.134	0.438 x 0.248
1.13/16	2.43	0.500 x 0.131	0.500 x 0.283
1.7/8	2.38	0.500 x 0.131	0.500 x 0.283
1.15/16	2.33	0.500 x 0.131	0.500 x 0.283
2	2.29	0.500 x 0.131	0.500 x 0.283
2.1/16	2.24	0.625 x 0.185	0.625 x 0.354
2.1/8	2.19	0.625 x 0.185	0.625 x 0.354
2.3/16	2.14	0.625 x 0.185	0.625 x 0.354
2.1/4	2.09	0.625 x 0.185	0.625 x 0.354
2.5/16	2.04	0.625 x 0.185	0.625 x 0.354
2.3/8	1.98	0.625 x 0.185	0.625 x 0.354
2.7/16	1.92	0.625 x 0.185	0.625 x 0.354
2.1/2	1.86	0.625 x 0.185	0.625 x 0.354
2.9/16	1.80	0.750 x 0.209	0.750 x 0.424
2.5/8	1.74	0.750 x 0.209	0.750 x 0.424
2.11/16	1.68	0.750 x 0.209	0.750 x 0.424
2.3/4	1.61	0.750 x 0.209	0.750 x 0.424
2.13/16	1.55	0.750 x 0.209	0.750 x 0.424
2.7/8	1.48	0.750 x 0.209	0.750 x 0.424
2.15/16	1.41	0.750 x 0.209	0.750 x 0.424
3	1.34	0.750 x 0.209	0.750 x 0.424

3030

Bore	Weight	Keyseat	
	kg †	Bush	Shaft
1.1/4	3.87	0.312 x 0.112	0.312 x 0.177
1.3/8	3.77	0.375 x 0.110	0.375 x 0.213
1.1/2	3.67	0.375 x 0.110	0.375 x 0.213
1.5/8	3.56	0.438 x 0.134	0.438 x 0.248
1.11/16	3.50	0.438 x 0.134	0.438 x 0.248
1.3/4	3.44	0.438 x 0.134	0.438 x 0.248
1.13/16	3.38	0.500 x 0.131	0.500 x 0.283
1.7/8	3.31	0.500 x 0.131	0.500 x 0.283
1.15/16	3.24	0.500 x 0.131	0.500 x 0.283
2	3.17	0.500 x 0.131	0.500 x 0.283
2.1/16	3.09	0.625 x 0.185	0.625 x 0.354
2.1/8	3.02	0.625 x 0.185	0.625 x 0.354
2.3/16	2.95	0.625 x 0.185	0.625 x 0.354
2.1/4	2.87	0.625 x 0.185	0.625 x 0.354
2.5/16	2.77	0.625 x 0.185	0.625 x 0.354
2.3/8	2.70	0.625 x 0.185	0.625 x 0.354
2.7/16	2.61	0.625 x 0.185	0.625 x 0.354
2.1/2	2.53	0.625 x 0.185	0.625 x 0.354
2.9/16	2.44	0.750 x 0.209	0.750 x 0.424
2.5/8	2.35	0.750 x 0.209	0.750 x 0.424
2.11/16	2.25	0.750 x 0.209	0.750 x 0.424
2.3/4	2.16	0.750 x 0.209	0.750 x 0.424
2.13/16	2.06	0.750 x 0.209	0.750 x 0.424
2.7/8	1.96	0.750 x 0.209	0.750 x 0.424
2.15/16	1.85	0.750 x 0.209	0.750 x 0.424
3	1.75	0.750 x 0.209	0.750 x 0.424

† Net weight including screws.

Bold italic type indicates bushes made of **steel**.

Keyways are parallel and in accordance with BS46: Part 1:1958, with the exception of those marked* which are shallower.

Depth of key measured at centre

All dimensions are in inches

Taper Bushes - Imperial

3525

Bore	Weight		Keyseat	
	kg †	Bush	Shaft	
1.1/2	4.83	0.375 x 0.110	0.375 x 0.213	
1.5/8	4.74	0.438 x 0.134	0.438 x 0.248	
1.9/16	4.71	0.438 x 0.134	0.438 x 0.248	
1.11/16	4.67	0.438 x 0.134	0.438 x 0.248	
1.3/4	4.64	0.438 x 0.134	0.438 x 0.248	
1.13/16	4.59	0.500 x 0.131	0.500 x 0.283	
1.7/8	4.53	0.500 x 0.131	0.500 x 0.283	
1.15/16	4.48	0.500 x 0.131	0.500 x 0.283	
2	4.41	0.500 x 0.131	0.500 x 0.283	
2.1/16	4.35	0.625 x 0.185	0.625 x 0.354	
2.1/8	4.29	0.625 x 0.185	0.625 x 0.354	
2.3/16	4.23	0.625 x 0.185	0.625 x 0.354	
2.1/4	4.16	0.625 x 0.185	0.625 x 0.354	
2.5/16	4.09	0.625 x 0.185	0.625 x 0.354	
2.3/8	4.02	0.625 x 0.185	0.625 x 0.354	
2.7/16	3.95	0.625 x 0.185	0.625 x 0.354	
2.1/2	3.88	0.625 x 0.185	0.625 x 0.354	
2.9/16	3.81	0.750 x 0.209	0.750 x 0.424	
2.5/8	3.73	0.750 x 0.209	0.750 x 0.424	
2.11/16	3.65	0.750 x 0.209	0.750 x 0.424	
2.3/4	3.57	0.750 x 0.209	0.750 x 0.424	
2.13/16	3.48	0.750 x 0.209	0.750 x 0.424	
2.7/8	3.40	0.750 x 0.209	0.750 x 0.424	
2.15/16	3.32	0.750 x 0.209	0.750 x 0.424	
3	3.23	0.750 x 0.209	0.750 x 0.424	
3.1/16	3.14	0.875 x 0.264	0.875 x 0.495	
3.1/8	3.04	0.875 x 0.264	0.875 x 0.495	
3.3/16	2.95	0.875 x 0.264	0.875 x 0.495	
3.1/4	2.85	0.875 x 0.264	0.875 x 0.495	
3.5/16	2.76	0.875 x 0.264	0.875 x 0.495	
3.3/8	2.66	0.875 x 0.264	0.875 x 0.495	
3.7/16	2.55	0.875 x 0.264	0.875 x 0.495	
3.1/2	2.45	0.875 x 0.264	0.875 x 0.495	
3.9/16	2.35	1.000 x 0.318	1.000 x 0.566	
3.11/16	2.25	1.000 x 0.318	1.000 x 0.566	
3.3/4*	2.15	1.000 x 0.245*	1.000 x 0.566	
3.13/16*	1.99	1.000 x 0.245*	1.000 x 0.566	
3.15/16*	1.82	1.000 x 0.155*	1.000 x 0.566	
4*	1.66	1.000 x 0.155*	1.000 x 0.566	

3535

Bore	Weight		Keyseat	
	kg †	Bush	Shaft	
1.1/2	6.43	0.375 x 0.110	0.375 x 0.213	
1.9/16	6.36	0.438 x 0.134	0.438 x 0.248	
1.5/8	6.30	0.438 x 0.134	0.438 x 0.248	
1.11/16	6.23	0.438 x 0.134	0.438 x 0.248	
1.3/4	6.16	0.438 x 0.134	0.438 x 0.248	
1.13/16	6.09	0.500 x 0.131	0.500 x 0.283	
1.7/8	6.01	0.500 x 0.131	0.500 x 0.283	
1.15/16	5.93	0.500 x 0.131	0.500 x 0.283	
2	5.85	0.500 x 0.131	0.500 x 0.283	
2.1/16	5.77	0.625 x 0.185	0.625 x 0.354	
2.1/8	5.68	0.625 x 0.185	0.625 x 0.354	
2.3/16	5.59	0.625 x 0.185	0.625 x 0.354	
2.1/4	5.49	0.625 x 0.185	0.625 x 0.354	
2.5/16	5.39	0.625 x 0.185	0.625 x 0.354	
2.3/8	5.30	0.625 x 0.185	0.625 x 0.354	
2.7/16	5.20	0.625 x 0.185	0.625 x 0.354	
2.1/2	5.10	0.625 x 0.185	0.625 x 0.354	
2.9/16	4.99	0.750 x 0.209	0.750 x 0.424	
2.5/8	4.88	0.750 x 0.209	0.750 x 0.424	
2.11/16	4.77	0.750 x 0.209	0.750 x 0.424	
2.3/4	4.66	0.750 x 0.209	0.750 x 0.424	
2.13/16	4.55	0.750 x 0.209	0.750 x 0.424	
2.7/8	4.43	0.750 x 0.209	0.750 x 0.424	
2.15/16	4.30	0.750 x 0.209	0.750 x 0.424	
3	4.18	0.750 x 0.209	0.750 x 0.424	
3.1/16	4.06	0.875 x 0.264	0.875 x 0.495	
3.1/8	3.93	0.875 x 0.264	0.875 x 0.495	
3.3/16	3.80	0.875 x 0.264	0.875 x 0.495	
3.1/4	3.66	0.875 x 0.264	0.875 x 0.495	
3.5/16	3.53	0.875 x 0.264	0.875 x 0.495	
3.3/8	3.39	0.875 x 0.264	0.875 x 0.495	
3.7/16	3.24	0.875 x 0.264	0.875 x 0.495	
3.1/2	3.10	0.875 x 0.264	0.875 x 0.495	

4030

Bore	Weight		Keyseat	
	kg †	Bush	Shaft	
1.3/4	7.38	0.438 x 0.134	0.438 x 0.248	
1.7/8	7.25	0.500 x 0.131	0.500 x 0.283	
2	7.12	0.500 x 0.131	0.500 x 0.283	
2.1/8	6.97	0.625 x 0.185	0.625 x 0.354	
2.1/4	6.81	0.625 x 0.185	0.625 x 0.354	
2.3/8	6.65	0.625 x 0.185	0.625 x 0.354	
2.1/2	6.47	0.625 x 0.185	0.625 x 0.354	
2.5/8	6.29	0.750 x 0.209	0.750 x 0.424	
2.3/4	6.10	0.750 x 0.209	0.750 x 0.424	
2.7/8	5.90	0.750 x 0.209	0.750 x 0.424	
3	5.69	0.750 x 0.209	0.750 x 0.424	
3.1/8	5.47	0.875 x 0.264	0.875 x 0.495	
3.1/4	5.24	0.875 x 0.264	0.875 x 0.495	
3.3/8	5.01	0.875 x 0.264	0.875 x 0.495	
3.1/2	4.67	0.875 x 0.264	0.875 x 0.495	
3.3/4	4.25	1.000 x 0.318	1.000 x 0.566	
4	3.69	1.000 x 0.318	1.000 x 0.566	
4.1/4	3.30	1.250 x 0.366	1.250 x 0.707	
4.1/2*	2.63	1.250 x 0.255*	1.250 x 0.707	

† Net weight including screws.

Bold italic type indicates bushes made of **GGG Cast Iron**.

Keyways are parallel and in accordance with BS46:Part 1:1958, with the exception of those marked* which are shallower.

Depth of key measured at centre.

All dimensions are in inches

Taper Bushes - Imperial

4040

Bore	Weight	Keyseat	
	kg †	Bush	Shaft
1.3/4	9.61	0.438 x 0.134	0.438 x 0.248
1.7/8	9.43	0.500 x 0.131	0.500 x 0.283
2	9.25	0.500 x 0.131	0.500 x 0.238
2.1/16	9.15	0.625 x 0.185	0.625 x 0.354
2.1/8	9.05	0.625 x 0.185	0.625 x 0.354
2.3/16	8.95	0.625 x 0.185	0.625 x 0.354
2.1/4	8.85	0.625 x 0.185	0.625 x 0.354
2.5/16	8.74	0.625 x 0.185	0.625 x 0.354
2.3/8	8.63	0.625 x 0.185	0.625 x 0.354
2.7/16	8.51	0.625 x 0.185	0.625 x 0.354
2.1/2	8.39	0.625 x 0.185	0.625 x 0.354
2.9/16	8.27	0.750 x 0.209	0.750 x 0.424
2.5/8	8.15	0.750 x 0.209	0.750 x 0.424
2.11/16	8.03	0.750 x 0.209	0.750 x 0.424
2.3/4	7.90	0.750 x 0.209	0.750 x 0.424
2.13/16	7.77	0.750 x 0.209	0.750 x 0.424
2.7/8	7.63	0.750 x 0.209	0.750 x 0.424
2.15/16	7.49	0.750 x 0.209	0.750 x 0.424
3	7.35	0.750 x 0.209	0.750 x 0.424
3.1/16	7.21	0.875 x 0.264	0.875 x 0.495
3.1/8	7.06	0.875 x 0.264	0.875 x 0.495
3.3/16	6.91	0.875 x 0.264	0.875 x 0.495
3.1/4	6.75	0.875 x 0.264	0.875 x 0.495
3.5/16	6.59	0.875 x 0.264	0.875 x 0.495
3.3/8	6.44	0.875 x 0.264	0.875 x 0.495
3.7/16	6.28	0.875 x 0.264	0.875 x 0.495
3.1/2	6.11	0.875 x 0.264	0.875 x 0.495
3.9/16	5.72	1.000 x 0.318	1.000 x 0.566
3.3/4	5.42	1.000 x 0.318	1.000 x 0.566
3.11/16	5.24	1.000 x 0.318	1.000 x 0.566
3.13/16	5.06	1.000 x 0.318	1.000 x 0.566
3.15/16	4.88	1.000 x 0.318	1.000 x 0.566
4	4.69	1.000 x 0.318	1.000 x 0.566

4535

Bore	Weight	Keyseat	
	kg †	Bush	Shaft
2.1/4	10.21	0.625 x 0.185	0.625 x 0.354
2.3/8	10.01	0.625 x 0.185	0.625 x 0.354
2.1/2	9.81	0.625 x 0.185	0.625 x 0.354
2.5/8	9.60	0.750 x 0.209	0.750 x 0.424
2.3/4	9.37	0.750 x 0.209	0.750 x 0.424
2.7/8	9.14	0.750 x 0.209	0.750 x 0.424
3	8.90	0.750 x 0.209	0.750 x 0.424
3.1/8	8.64	0.875 x 0.264	0.875 x 0.495
3.1/4	8.38	0.875 x 0.264	0.875 x 0.495
3.3/8	8.10	0.875 x 0.264	0.875 x 0.495
3.1/2	7.81	0.875 x 0.264	0.875 x 0.495
3.3/4	7.21	1.000 x 0.318	1.000 x 0.566
4	6.56	1.000 x 0.318	1.000 x 0.566
4.1/4	5.88	1.250 x 0.366	1.250 x 0.707
4.1/2	5.15	1.250 x 0.366	1.250 x 0.707
4.3/4	4.65	1.250 x 0.366	1.250 x 0.707
5*	3.78	1.250 x 0.358*	1.250 x 0.707

4545

Bore	Weight	Keyseat	
	kg †	Bush	Shaft
2.3/16	13.69	0.625 x 0.185	0.625 x 0.354
2.1/4	13.56	0.625 x 0.185	0.625 x 0.354
2.5/16	13.44	0.625 x 0.185	0.625 x 0.354
2.3/8	13.32	0.625 x 0.185	0.625 x 0.354
2.7/16	13.19	0.625 x 0.185	0.625 x 0.354
2.1/2	13.06	0.625 x 0.185	0.625 x 0.354
2.5/8	12.78	0.750 x 0.209	0.750 x 0.424
2.3/4	12.50	0.750 x 0.209	0.750 x 0.424
2.7/8	12.19	0.750 x 0.209	0.750 x 0.424
3	11.88	0.750 x 0.209	0.750 x 0.424
3.1/16	11.72	0.875 x 0.264	0.875 x 0.495
3.1/8	11.55	0.875 x 0.264	0.875 x 0.495
3.1/4	11.21	0.875 x 0.264	0.875 x 0.495
3.3/8	10.86	0.875 x 0.264	0.875 x 0.495
3.7/16	10.68	0.875 x 0.264	0.875 x 0.495
3.1/2	10.49	0.875 x 0.264	0.875 x 0.495
3.9/16	10.11	1.000 x 0.318	1.000 x 0.566
3.3/4	9.72	1.000 x 0.318	1.000 x 0.566
3.13/16	9.28	1.000 x 0.318	1.000 x 0.566
4	8.89	1.000 x 0.318	1.000 x 0.566
4.1/4	8.00	1.250 x 0.366	1.250 x 0.707
4.5/16	7.54	1.250 x 0.366	1.250 x 0.707
4.1/2	7.07	1.250 x 0.366	1.250 x 0.707

5040

Bore	Weight	Keyseat	
	kg †	Bush	Shaft
3	12.88	0.750 x 0.209	0.750 x 0.424
3.1/8	12.59	0.875 x 0.264	0.875 x 0.495
3.1/4	12.29	0.875 x 0.264	0.875 x 0.495
3.3/8	11.97	0.875 x 0.264	0.875 x 0.495
3.1/2	11.65	0.875 x 0.264	0.875 x 0.495
3.3/4	10.96	1.000 x 0.318	1.000 x 0.566
4	10.22	1.000 x 0.318	1.000 x 0.566
4.1/4	9.44	1.250 x 0.366	1.250 x 0.707
4.1/2	8.61	1.250 x 0.366	1.250 x 0.707
4.3/4	7.73	1.250 x 0.366	1.250 x 0.707
5	6.80	1.250 x 0.366	1.250 x 0.707

† Net weight including screws.

Bold italic type indicates bushes made of **GGG Cast Iron**.

Keyways are parallel and in accordance with BS46:Part 1:1958, with the exception of those marked* which are shallower.

Depth of key measured at centre.

All dimensions are in inches

Taper Bushes - Imperial

5050

Bore	Weight	Keyseat	
	kg †	Bush	Shaft
3	15.66	0.750 x 0.209	0.750 x 0.424
3.1/8	15.30	0.875 x 0.264	0.875 x 0.495
3.1/4	14.92	0.875 x 0.264	0.875 x 0.495
3.7/16	14.52	0.875 x 0.264	0.875 x 0.495
3.1/2	14.12	0.875 x 0.264	0.875 x 0.495
3.3/4	13.26	1.000 x 0.318	1.000 x 0.566
4	12.34	1.000 x 0.318	1.000 x 0.566
4.1/4	11.36	1.250 x 0.366	1.250 x 0.707
4.7/16	10.84	1.250 x 0.366	1.250 x 0.707
4.1/2	10.32	1.250 x 0.366	1.250 x 0.707
4.3/4	9.22	1.250 x 0.366	1.250 x 0.707
5	8.06	1.250 x 0.366	1.250 x 0.707

† Net weight including screws.

Keyways are parallel and in accordance with BS46:Part 1:1958, with the exception of those marked* which are shallower.

Depth of key measured at centre.

All dimensions are in inches

NOTE

Challenge can manufacture larger taper bush sizes including 6050, 7060 and 8065. These are available to order with the following maximum bores:

6050 150 mm or 6"

7060 175 mm or 7"

8065 200 mm or 8"

Pilot bore taper bushes in these sizes are also available.

Adaptors

Adaptors

Hub Type	A	B	Key Section
1008PM	22	45	-
1008KM	22	45	5 x 5
1210PM	25	60	-
1210KM	25	60	6 x 6
1610PM	25	70	-
1610KM	25	70	10 x 8
2517PM	45	105	-
2517KM	45	105	16 x 10
3030PM	76	130	-
3030KM	76	130	20 x 12
3535PM	90	160	-
3535KM	90	160	22 x 12
4040PM	102	185	-
4040KM	102	185	24 x 12

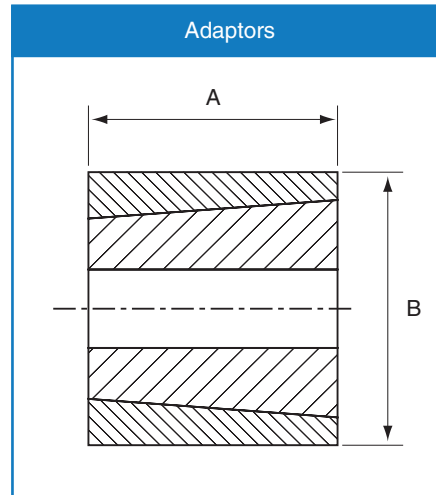

Adaptors for Pilot Bored components allow them to take standard Taper Bushes. This added convenience removes the need to drill, tap and taper-bore.

PM = Plain outside diameter

KM = Keyway on outside diameter allowing additional torque transmission

Bolt-on-Hubs

Taper Bore Bolt-on-Hubs are designed for use with the universally accepted Taper Bush. They provide a convenient means of securing fan rotors, impellers, agitators and other devices which must be fastened firmly to shafts.

Challenge Bolt-on-Hubs, type BF and SM, complete the range. They are manufactured from GG22 cast iron and are phosphated for extra rust protection.

SM Bolt-on-Hubs

Hub Reference	Bush Number	A	B	C	D	E	F/G	H	J (No. x Diam)
SM 12	1210	180	90	135	26	6.5	80	9.75	6 x 7.5
SM 16-1	1610	200	110	150	26	7.5	90	9.25	6 x 7.5
SM 16-2	1615	200	110	150	38	7.5	90	15.25	6 x 7.5
SM 20	2012	270	140	190	32	8.5	100	11.75	6 x 9.5
SM 25	2517	340	170	240	45	9.5	119	17.75	8 x 11.5
SM 30-1	3020	430	220	300	51	13.5	147	18.75	8 x 13.5
SM 30-2	3020	485	250	340	51	13.5	147	18.75	8 x 13.5

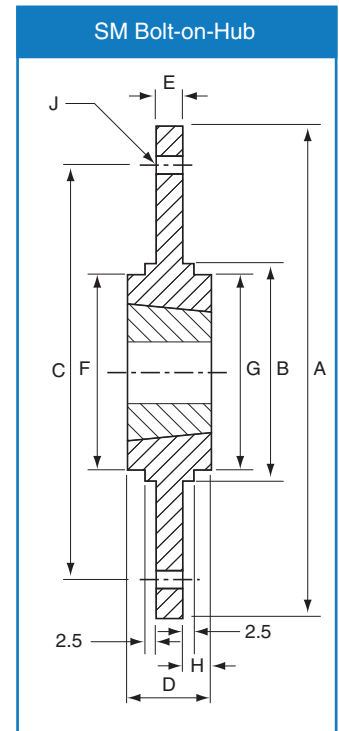

BF Bolt-on-Hubs

Hub Reference	Bush Number	A	B	C	D	E	F	G	H	J (No. x Diam)
BF12	1210	120	80	100	25	6.5	74	80	10	6 x 6.5
BF16	1610	130	90	110	25	6.5	84	90	10	6 x 6.5
BF20	2012	145	100	125	32	8.5	99	100	13	6 x 8.5
BF25	2517	185	130	155	44	11.5	120	119	20	6 x 10.5
BF30	3020	220	165	190	50	11.5	146	147	20	6 x 13.0

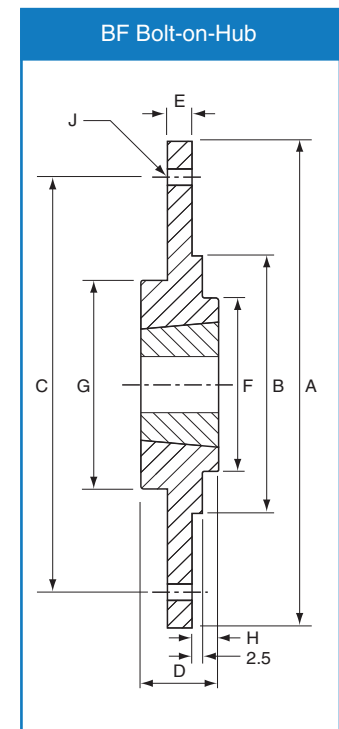

Weld-on-Hubs

Taper Bore Weld-on-Hubs are made out of steel, drilled, tapped and taper bored to receive standard Taper Bushes. The extended flange provides a convenient means of welding hubs into fan rotors, steel pulleys, plate sprockets, impellers, agitators and many other devices which must be firmly fastened to the shaft.

Challenge Weld-on-Hubs are manufactured to complement the Taper Bush range and include W, WH and WM Taper Bore Hubs. All are manufactured to world standards using low carbon steel.

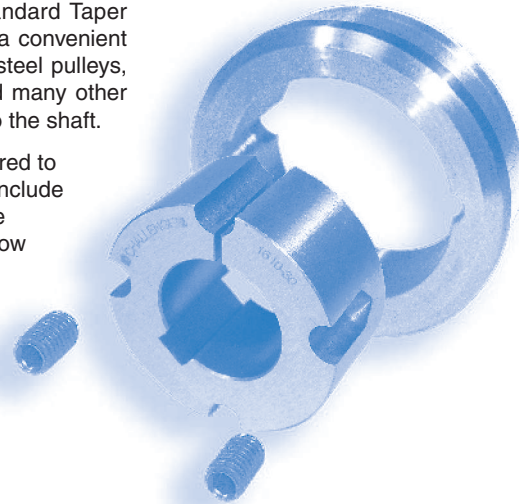

Typical Assembly

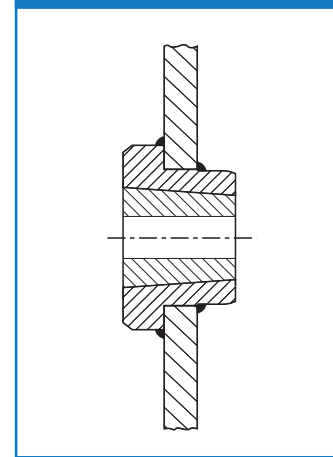

W Weld-on-Hubs

Hub Reference	Bush Size	A	B	C	D	E	F	F1	X
W12	1215	73.03	63.50	62.71	38.10	15.88	9.53	-	-
W16	1615	82.55	73.03	72.24	38.10	15.88	9.53	-	-
W25	2517	127.00	111.13	110.34	44.45	19.05	12.70	-	-
WG30	3030	149.86	133.35	132.56	76.20	25.40	19.05	23	23
WG35	3535	184.15	158.75	157.96	88.90	31.75	25.40	30	30
WG40	4040	225.43	196.85	196.06	101.60	31.75	31.75	34	34
WG45	4545	254.00	222.25	221.46	114.30	38.10	38.10	38	38
WG50	5050	276.00	241.00	240.25	127.00	38.10	38.10	42	42
WG60	6050	375.00	343.00	342.00	127.00	38.10	38.10	42	42
WG70	7060	425.00	375.00	374.00	153.00	51.00	51.00	51	51
WG80	8065	445.00	394.00	393.00	165.00	51.00	51.00	55	55
WG100	10085	559.00	495.00	494.00	216.00	51.00	51.00	72	72

"G" notation represents welding relief.

W & WH Weld-on-Hub

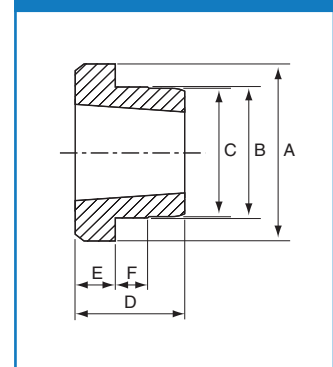

WH Weld-on-Hubs

Hub Reference	Bush Size	A	B	C	D	E	F	F1	X
WH12	1210	70	65	64.5	25	9	10	-	-
WH16-1	1610	80	75	74.5	25	9	10	-	-
WH20	2012	95	90	89.5	32	12	12	-	-
WH25	2517	115	110	109.5	44	19	15	-	-
WHG30-2	3020	145	140	139.5	50	20	15	17	17
WHG35	3525	190	180	179.5	65	25	25	22	22
WHG40-1	4030	200	190	189.0	76	32	30	25	25
WHG40-2	4040	200	190	189.5	101	32	30	34	34
WHG45-1	4535	210	200	199.5	89	40	30	30	30
WHG45-2	4545	210	200	199.5	114	40	30	38	38
WHG50-1	5040	230	220	219.5	102	40	35	34	34
WHG50-2	5050	230	220	219.5	127	40	35	42	42

"G" notation represents welding relief.

WG & WHG Weld-on-Hub

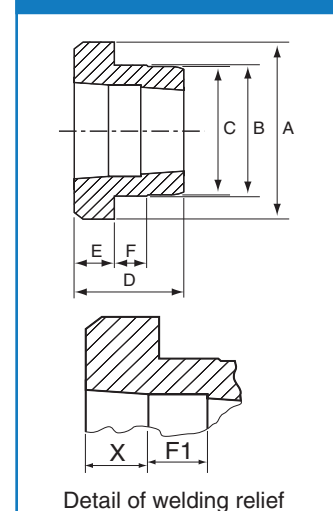

Weld-on-Hubs

WM Weld-on-Hubs

Hub Reference	Bush Size	A	B	C	D	E	F	F1	X
WMG12	1210	70	60	58	26	9	10	9	9
WMG16-1	1610	83	70	68	26	9	10	9	9
WMG16-2	1615	83	70	68	38	16	11	13	13
WMG20	2012	95	90	88	32	12	12	11	11
WMG25	2517	127	110	108	44	19	13	15	15
WMG30-2	3020	152	130	125	50	20	15	17	17
WMG30-3	3030	152	130	125	76	25	19	25	25
WMG35	3535	184	155	151	89	32	25	30	30
WMG40	4040	225	195	187	102	32	32	34	34
WMG45	4545	254	220	213	114	38	38	38	38
WMG50	5050	276	242	228	127	38	38	42	42

"G" notation represents welding relief.

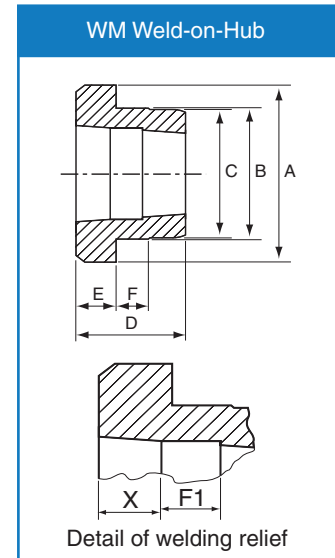

Edisonweg 5
4631SN Hoogerheide
0164-611000
technik@overveldtechniek.com
www.overveldtechniek.com