

ASKUBAL® Rod ends and spherical bearings

Mating Materials:
Steel on high-duty bronze
Maintenance required

Standard
DIN ISO 12240-4
dimension series K

- Inner ring:** Antifriction bearing steel, hardened, ground and polished.
- Outer ring:** Sliding face made of high-duty bronze. Lubricant is distributed via the lubrication groove in the outer ring.
- Housing:** Sizes 3 to 12 free-cutting steel, sizes 14 to 50 tempering steel (standardised), all sizes galvanized and chromatised. The spherical bearing is pressed into the housing and caulked at both sides.
- Lubrication nipple:** Sizes 3 and 5 without lubrication nipple. Sizes 6 to 50 lubrication nipple DIN 3405, shape D. Further lubrication nipple shapes available on request.

Female thread

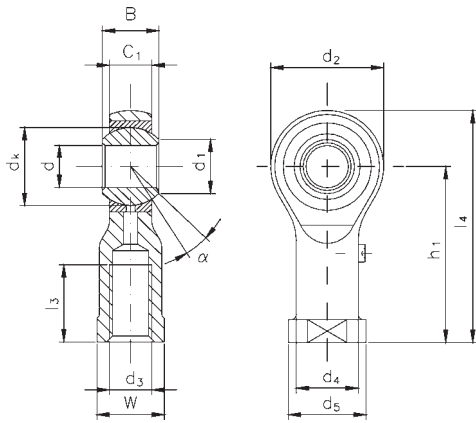

Designation		d	d ₃	B	C ₁	d ₁ ≈
Righthand thread	Lefthand thread	mm	mm	mm	mm	mm
KI 3	KIL 3	3	M3	6	4.50	5.1
KI 5	KIL 5	5	M5	8	6.00	7.7
KI 6	KIL 6	6	M6	9	6.75	8.9
KI 8	KIL 8	8	M8	12	9.00	10.3
KI 10	KIL 10	10	M10	14	10.50	12.9
KI 12	KIL 12	12	M12	16	12.00	15.4
KI 14	KIL 14	14	M14	19	13.50	16.8
KI 16	KIL 16	16	M16	21	15.00	19.3
KI 18	KIL 18	18	M18x1.5	23	16.50	21.8
KI 20	KIL 20	20	M20x1.5	25	18.00	24.3
KI 22	KIL 22	22	M22x1.5	28	20.00	25.8
KI 25	KIL 25	25	M24x2	31	22.00	29.5
KI 30	KIL 30	30	M30x2	37	25.00	34.8
KI 35	KIL 35	35	M36x2	43	28.00	37.7*
KI 40	KIL 40	40	M42x2	49	33.00	45.2*
KI 50	KIL 50	50	M48x2	60	45.00	56.6*

*) deviates from standard

Male thread

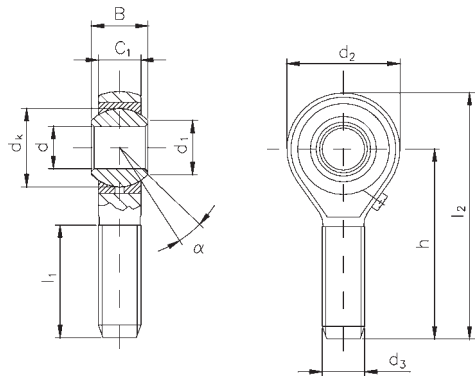

Designation		d	d ₃	B	C ₁	d ₁ ≈
Righthand thread	Lefthand thread	mm	mm	mm	mm	mm
KA 3	KAL 3	3	M3	6	4.50	5.1
KA 5	KAL 5	5	M5	8	6.00	7.7
KA 6	KAL 6	6	M6	9	6.75	8.9
KA 8	KAL 8	8	M8	12	9.00	10.3
KA 10	KAL 10	10	M10	14	10.50	12.9
KA 12	KAL 12	12	M12	16	12.00	15.4
KA 14	KAL 14	14	M14	19	13.50	16.8
KA 16	KAL 16	16	M16	21	15.00	19.3
KA 18	KAL 18	18	M18x1.5	23	16.50	21.8
KA 20	KAL 20	20	M20x1.5	25	18.00	24.3
KA 22	KAL 22	22	M22x1.5	28	20.00	25.8
KA 25	KAL 25	25	M24x2	31	22.00	29.5
KA 30	KAL 30	30	M30x2	37	25.00	34.8
KA 35	KAL 35	35	M36x2	43	28.00	37.7*
KA 40	KAL 40	40	M42x2	49	33.00	45.2*
KA 50	KAL 50	50	M48x2	60	45.00	56.6*

*) deviates from standard

Special versions:

- **Version -V:**
as standard, but housing heat-treated,
for static load capacity see **-V** load rating stat **C0**
- **Version -L:**
as standard, but housing made from high-grade tempering steel (heat-treated),
for static load capacity see **-L** load rating stat **C0**

Further versions available on request. E.g.:

- Housing crack-tested
- Sliding face of inner ring hard chromium plated
- Special surface coating of housing

d ₂ max.	d ₄ ≈	d ₅	d _k	h ₁	l ₃ min.	l ₄ ≈	W	Load ratings static C ₀			Tilt angle α°	Weight kg
								Standard	-V	-L		
mm	mm	mm	mm	mm	mm	mm	mm	kN	kN	kN	°	kg
15	6.5	8	7.9	21	8	28.5	7	4	•	•	13	0.008
19	9.0	11	11.1	27	8	36.5	9	6	•	•	13	0.017
21	10.0	13	12.7	30	9	40.5	11	7	•	•	13	0.025
25	12.5	16	15.8	36	12	48.5	14	12	16	21	13	0.043
29	15.0	19	19.0	43	15	57.5	17	15	19	27	13	0.072
33	17.5	22	22.2	50	18	66.5	19	23	25	35	13	0.107
37	20.0	25	25.4	57	21	75.5	22	24	34	46	15	0.160
43	22.0	27	28.5	64	24	85.5	22	34	43	57	15	0.210
47	25.0	31	31.7	71	27	94.5	27	39	49	77	15	0.295
51	27.5	34	34.9	77	30	102.5	30	42	50	78	15	0.380
55	30.0	37	38.1	84	33	111.5	32	54	70	101	15	0.490
61	33.5	42	42.8	94	36	124.5	36	60	78	131	15	0.650
71	40.0	50	50.8	110	45	145.5	41	82	107	182	15	1.150
81	46.0	58	57.1	125	56	165.5	50	96	•	•	16	1.600
91	53.0	65	66.6	142	60	187.5	55	145	•	•	17	2.400
117	65.0	75	82.5	160	65	218.5	65	209	•	•	12	5.000

• not available

d ₂ max.	d _k	h	l ₁ min.	l ₂ ≈	Load ratings static C ₀			Tilt angle α°	Weight kg	
					Standard	-V	-L			
mm	mm	mm	mm	mm	mm	kN	kN	kN	°	kg
15	7.9	27	15	34.0	1	•	•	13	0.005	
19	11.1	33	19	42.5	3	•	•	13	0.013	
21	12.7	36	21	46.5	4	•	•	13	0.019	
25	15.8	42	25	54.5	8	10	17	13	0.032	
29	19.0	48	28	62.5	13	17	25	13	0.054	
33	22.2	54	32	70.5	21	22	33	13	0.085	
37	25.4	60	36	78.5	22	31	44	15	0.125	
43	28.5	66	37	87.5	33	43	57	15	0.185	
47	31.7	72	41	95.5	39	49	77	15	0.260	
51	34.9	78	45	103.5	42	50	78	15	0.340	
55	38.1	84	48	111.5	54	70	101	15	0.435	
61	42.8	94	55	124.5	60	78	131	15	0.590	
71	50.8	110	66	145.5	82	107	182	15	1.060	
81	57.0	140	85	180.5	96	•	•	16	1.640	
91	66.0	150	90	195.5	132	•	•	17	2.300	
117	82.0	185	105	219.5	209	•	•	12	4.800	

• not available

Mating materials:
Steel on PTFE
Maintenance-free

Standard
DIN ISO 12240-4
dimension series K

Inner ring: Antifriction bearing steel, hardened, ground and polished.

Outer ring: Steel lined with an antifriction film, consisting of PTFE.

Housing: Sizes 5 to 12 free-cutting steel, sizes 14 to 50 tempering steel (standardised), all sizes galvanized and chromatised. The spherical bearing is pressed into the housing and caulked at both sides.

Female thread

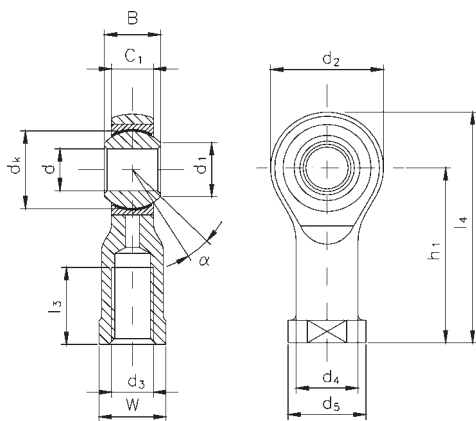

Designation		d	d ₃	B	C ₁	d ₁
Righthand thread	Lefthand thread	mm	mm	mm	mm	mm
KI 5-D	KIL 5-D	5	M5	8	6.00	7.7
KI 6-D	KIL 6-D	6	M6	9	6.75	8.9
KI 8-D	KIL 8-D	8	M8	12	9.00	10.3
KI 10-D	KIL 10-D	10	M10	14	10.50	12.9
KI 12-D	KIL 12-D	12	M12	16	12.00	15.4
KI 14-D	KIL 14-D	14	M14	19	13.50	16.8
KI 16-D	KIL 16-D	16	M16	21	15.00	19.3
KI 18-D	KIL 18-D	18	M18x1.5	23	16.50	21.8
KI 20-D	KIL 20-D	20	M20x1.5	25	18.00	24.3
KI 22-D	KIL 22-D	22	M22x1.5	28	20.00	25.8
KI 25-D	KIL 25-D	25	M24x2	31	22.00	29.5
KI 30-D	KIL 30-D	30	M30x2	37	25.00	34.8
KI 35-D	KIL 35-D	35	M36x2	43	28.00	37.7*
KI 40-D	KIL 40-D	40	M42x2	49	33.00	45.2*
KI 50-D	KIL 50-D	50	M48x2	60	45.00	56.6*

*) deviates from standard

Male thread

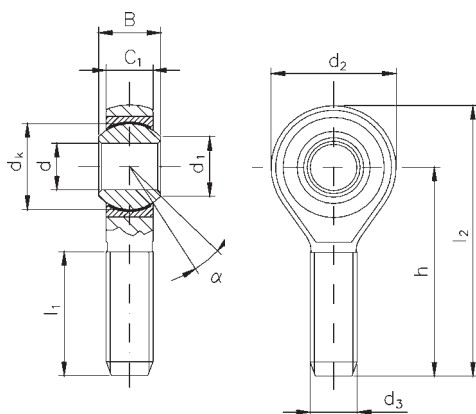

Designation		d	d ₃	B	C ₁	d ₁
Righthand thread	Lefthand thread	mm	mm	mm	mm	mm
KA 5-D	KAL 5-D	5	M5	8	6.00	7.7
KA 6-D	KAL 6-D	6	M6	9	6.75	8.9
KA 8-D	KAL 8-D	8	M8	12	9.00	10.3
KA 10-D	KAL 10-D	10	M10	14	10.50	12.9
KA 12-D	KAL 12-D	12	M12	16	12.00	15.4
KA 14-D	KAL 14-D	14	M14	19	13.50	16.8
KA 16-D	KAL 16-D	16	M16	21	15.00	19.3
KA 18-D	KAL 18-D	18	M18x1.5	23	16.50	21.8
KA 20-D	KAL 20-D	20	M20x1.5	25	18.00	24.3
KA 22-D	KAL 22-D	22	M22x1.5	28	20.00	25.8
KA 25-D	KAL 25-D	25	M24x2	31	22.00	29.5
KA 30-D	KAL 30-D	30	M30x2	37	25.00	34.8
KA 35-D	KAL 35-D	35	M36x2	43	28.00	37.7*
KA 40-D	KAL 40-D	40	M42x2	49	33.00	45.2*
KA 50-D	KAL 50-D	50	M48x2	60	45.00	56.6*

*) deviates from standard

Special versions:

- **Version -DMS:**
as standard, but outer ring made of brass
- **Version -DV:**
as standard, but housing heat-treated,
for static load capacity see **-V** load rating stat **C0**
- **Version -DL:**
as standard, but housing made from high-grade tempering steel (heat-treated),
for static load capacity see **-L** load rating stat **C0**

Further versions available on request. E.g.:

- Housing crack-tested
- Sliding face of inner ring hard chromium plated
- Special surface coating of housing

d ₂ max.	d ₄ ≈	d ₅	dk	h ₁	l ₃ min.	l ₄ ≈	W	Load ratings static C ₀			Tilt angle	Weight
								Standard	-V	-L		
mm	mm	mm	mm	mm	mm	mm	mm	kN	kN	kN	α°	kg
19	9.0	11	11.1	27	8	36.5	9	6	•	•	13	0.017
21	10.0	13	12.7	30	9	40.5	11	7	•	•	13	0.025
25	12.5	16	15.8	36	12	48.5	14	12	16	21	13	0.043
29	15.0	19	19.0	43	15	57.5	17	15	19	27	13	0.072
33	17.5	22	22.2	50	18	66.5	19	23	25	35	13	0.107
37	20.0	25	25.4	57	21	75.5	22	24	34	46	15	0.160
43	22.0	27	28.5	64	24	85.5	22	34	43	57	15	0.210
47	25.0	31	31.7	71	27	94.5	27	39	49	77	15	0.295
51	27.5	34	34.9	77	30	102.5	30	42	50	78	15	0.380
55	30.0	37	38.1	84	33	111.5	32	54	70	101	15	0.490
61	33.5	42	42.8	94	36	124.5	36	60	78	131	15	0.650
71	40.0	50	50.8	110	45	145.5	41	82	107	182	15	1.150
81	46.0	58	57.1	125	56	165.5	50	96	•	•	16	1.600
91	53.0	65	66.6	142	60	187.5	55	132	•	•	17	2.400
117	65.0	75	82.5	160	65	218.5	65	209	•	•	12	5.000

• not available

d ₂ max.	dk	h	l ₁ min.	l ₂ ≈	Load ratings static C ₀			Tilt angle	Weight	
					Standard	-V	-L			
mm	mm	mm	mm	mm	mm	kN	kN	kN	α°	kg
19	11.1	33	19	42.5	4	•	•	13	0.013	
21	12.7	36	21	46.5	6	•	•	13	0.019	
25	15.8	42	25	54.5	10	12	19	13	0.032	
29	19.0	48	28	62.5	15	19	27	13	0.054	
33	22.2	54	32	70.5	23	25	35	13	0.085	
37	25.4	60	36	78.5	24	34	46	15	0.125	
43	28.5	66	37	87.5	33	43	57	15	0.185	
47	31.7	72	41	95.5	39	49	77	15	0.260	
51	34.9	78	45	103.5	42	50	78	15	0.340	
55	38.1	84	48	111.5	54	70	101	15	0.435	
61	42.8	94	55	124.5	60	78	131	15	0.590	
71	50.8	110	66	145.5	82	107	182	15	1.060	
81	57.1	140	85	180.5	96	•	•	16	1.640	
91	66.6	150	90	195.5	132	•	•	17	2.300	
117	82.5	185	105	219.5	209	•	•	12	4.800	

• not available

Mating materials:
Stainless steel on high-duty bronze
Maintenance required

Stainless steel
DIN ISO 12240-4
dimension series K

- Inner ring:** Stainless steel, hardened, ground and polished.
- Outer ring:** Sliding face made of high-duty bronze. Lubricant is distributed via the lubricating groove in the outer ring.
- Housing:** Stainless steel. The spherical bearing is pressed into the housing and caulked at both sides.
- Lubrication nipple:** Size 5 without lubrication nipple. Sizes 6 to 30 lubricating nipple DIN 3405, shape D. Further lubricating nipple shapes available on request.

Female thread

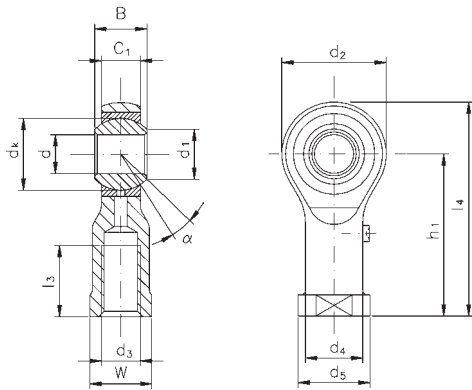

Designation		d	d ₃	B	C ₁	d ₁
Righthand thread	Lefthand thread	mm	mm	mm	mm	mm
KI 5-NR	KIL 5-NR	5	M5	8	6.00	7.7
KI 6-NR	KIL 6-NR	6	M6	9	6.75	8.9
KI 8-NR	KIL 8-NR	8	M8	12	9.00	10.3
KI 10-NR	KIL 10-NR	10	M10	14	10.50	12.9
KI 12-NR	KIL 12-NR	12	M12	16	12.00	15.4
KI 14-NR	KIL 14-NR	14	M14	19	13.50	16.8
KI 16-NR	KIL 16-NR	16	M16	21	15.00	19.3
KI 18-NR	KIL 18-NR	18	M18x1.5	23	16.50	21.8
KI 20-NR	KIL 20-NR	20	M20x1.5	25	18.00	24.3
KI 22-NR	KIL 22-NR	22	M22x1.5	28	20.00	25.8
KI 25-NR	KIL 25-NR	25	M24x2	31	22.00	29.5
KI 30-NR	KIL 30-NR	30	M30x2	37	25.00	34.8

Male thread

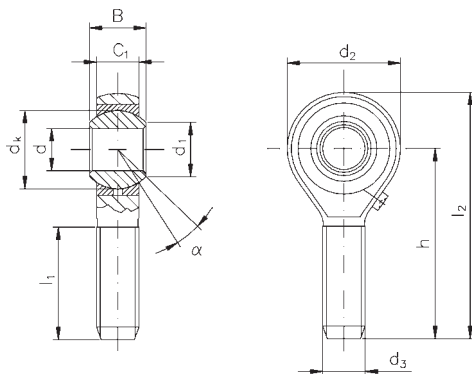

Designation		d	d ₃	B	C ₁	d ₁
Righthand thread	Lefthand thread	mm	mm	mm	mm	mm
KA 5-NR	KAL 5-NR	5	M5	8	6.00	7.7
KA 6-NR	KAL 6-NR	6	M6	9	6.75	8.9
KA 8-NR	KAL 8-NR	8	M8	12	9.00	10.3
KA 10-NR	KAL 10-NR	10	M10	14	10.50	12.9
KA 12-NR	KAL 12-NR	12	M12	16	12.00	15.4
KA 14-NR	KAL 14-NR	14	M14	19	13.50	16.8
KA 16-NR	KAL 16-NR	16	M16	21	15.00	19.3
KA 18-NR	KAL 18-NR	18	M18x1.5	23	16.50	21.8
KA 20-NR	KAL 20-NR	20	M20x1.5	25	18.00	24.3
KA 22-NR	KAL 22-NR	22	M22x1.5	28	20.00	25.8
KA 25-NR	KAL 25-NR	25	M24x2	31	22.00	29.5
KA 30-NR	KAL 30-NR	30	M30x2	37	25.00	34.8

Sizes 18 and 22 only on request.

Special versions:
- Version -R:

as standard, but inner ring made of 100Cr6 hard chromium plated at sliding surface

Further versions are available on request

d_2 max. mm	d_4 ≈ mm	d_5 mm	d_k mm	h_1 mm	l_3 min. mm	l_4 ≈ mm	W mm	Load rating static C_0 kN	Tilt angle α°	Weight kg
19	9.0	11	11.1	27	8	36.5	9	6	13	0.017
21	10.0	13	12.7	30	9	40.5	11	7	13	0.025
25	12.5	16	15.8	36	12	48.5	14	10	13	0.043
29	15.0	19	19.0	43	15	57.5	17	13	13	0.072
33	17.5	22	22.2	50	18	66.5	19	15	13	0.107
37	20.0	25	25.4	57	21	75.5	22	22	15	0.160
43	22.0	27	28.5	64	24	85.5	22	28	15	0.210
47	25.0	31	31.7	71	27	94.5	27	35	15	0.295
51	27.5	34	34.9	77	30	102.5	30	41	15	0.380
55	30.0	37	38.1	84	33	111.5	32	51	15	0.490
61	33.5	42	42.8	94	36	124.5	36	58	15	0.650
71	40.0	50	50.8	110	45	145.5	41	80	15	1.150

d_2 max. mm	d_k mm	h mm	l_1 min. mm	l_2 ≈ mm	Load rating static C_0 kN	Tilt angle α°	Weight kg
19	11.1	33	19	42.5	3	13	0.013
21	12.7	36	21	46.5	4	13	0.019
25	15.8	42	25	54.5	6	13	0.032
29	19.0	48	28	62.5	11	13	0.054
33	22.2	54	32	70.5	15	13	0.085
37	25.4	60	36	78.5	22	15	0.125
43	28.5	66	37	87.5	28	15	0.185
47	31.7	72	41	95.5	35	15	0.260
51	34.9	78	45	103.5	41	15	0.340
55	38.1	84	48	111.5	51	15	0.435
61	42.8	94	55	124.5	58	15	0.590
71	50.8	110	66	145.5	80	15	1.060

Mating materials:
Stainless steel on PTFE
Maintenance-free

Stainless steel
 DIN ISO 12240-4
 dimension series K

Inner ring: Stainless steel, hardened, ground and polished.

Outer ring: Brass lined with an antifriction film, consisting of PTFE, outer diameter ground.

Housing: Stainless steel. The spherical bearing is pressed into the housing and caulked at both sides.

Female thread

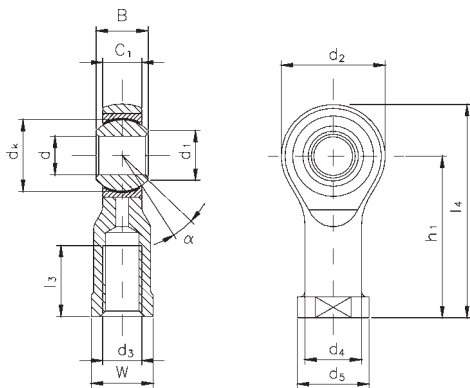

Designation		d	d ₃	B	C ₁	d ₁
Righthand thread	Lefthand thread	mm	mm	mm	mm	mm
KI 5-DNR	KIL 5-DNR	5	M5	8	6.00	7.7
KI 6-DNR	KIL 6-DNR	6	M6	9	6.75	8.9
KI 8-DNR	KIL 8-DNR	8	M8	12	9.00	10.3
KI 10-DNR	KIL 10-DNR	10	M10	14	10.50	12.9
KI 12-DNR	KIL 12-DNR	12	M12	16	12.00	15.4
KI 14-DNR	KIL 14-DNR	14	M14	19	13.50	16.8
KI 16-DNR	KIL 16-DNR	16	M16	21	15.00	19.3
KI 18-DNR	KIL 18-DNR	18	M18x1.5	23	16.50	21.8
KI 20-DNR	KIL 20-DNR	20	M20x1.5	25	18.00	24.3
KI 22-DNR	KIL 22-DNR	22	M22x1.5	28	20.00	25.8
KI 25-DNR	KIL 25-DNR	25	M24x2	31	22.00	29.5
KI 30-DNR	KIL 30-DNR	30	M30x2	37	25.00	34.8

Male thread

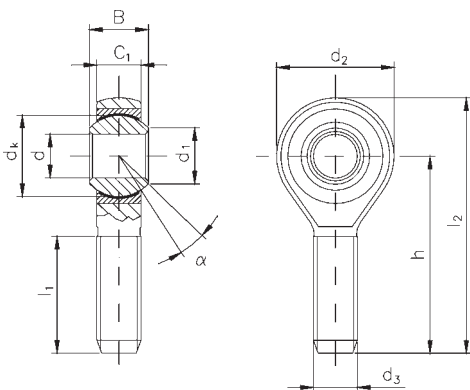

Designation		d	d ₃	B	C ₁	d ₁
Righthand thread	Lefthand thread	mm	mm	mm	mm	mm
KA 5-DNR	KAL 5-DNR	5	M5	8	6.00	7.7
KA 6-DNR	KAL 6-DNR	6	M6	9	6.75	8.9
KA 8-DNR	KAL 8-DNR	8	M8	12	9.00	10.3
KA 10-DNR	KAL 10-DNR	10	M10	14	10.50	12.9
KA 12-DNR	KAL 12-DNR	12	M12	16	12.00	15.4
KA 14-DNR	KAL 14-DNR	14	M14	19	13.50	16.8
KA 16-DNR	KAL 16-DNR	16	M16	21	15.00	19.3
KA 18-DNR	KAL 18-DNR	18	M18x1.5	23	16.50	21.8
KA 20-DNR	KAL 20-DNR	20	M20x1.5	25	18.00	24.3
KA 22-DNR	KAL 22-DNR	22	M22x1.5	28	20.00	25.8
KA 25-DNR	KAL 25-DNR	25	M24x2	31	22.00	29.5
KA 30-DNR	KAL 30-DNR	30	M30x2	37	25.00	34.8

Sizes 18 and 22 only on request.

Special versions:
- Version -DR:

as standard, but inner ring made of 100Cr6 hard chromium plated at sliding surface

Further versions are available on request

d ₂ max. mm	d ₄ ≈ mm	d ₅ mm	dk mm	h ₁ mm	l ₃ min. mm	l ₄ ≈ mm	W mm	Load rating static C ₀ kN	Tilt angle α°	Weight kg
19	9.0	11	11.1	27	8	36.5	9	6	13	0.017
21	10.0	13	12.7	30	9	40.5	11	7	13	0.025
25	12.5	16	15.8	36	12	48.5	14	10	13	0.043
29	15.0	19	19.0	43	15	57.5	17	13	13	0.072
33	17.5	22	22.2	50	18	66.5	19	15	13	0.107
37	20.0	25	25.4	57	21	75.5	22	22	15	0.160
43	22.0	27	28.5	64	24	85.5	22	28	15	0.210
47	25.0	31	31.7	71	27	94.5	27	35	15	0.295
51	27.5	34	34.9	77	30	102.5	30	41	15	0.380
55	30.0	37	38.1	84	33	111.5	32	51	15	0.490
61	33.5	42	42.8	94	36	124.5	36	58	15	0.650
71	40.0	50	50.8	110	45	145.5	41	80	15	1.150

d ₂ max. mm	dk mm	h mm	l ₁ min. mm	l ₂ ≈ mm	Load rating static C ₀ kN	Tilt angle α°	Weight kg
19	11.1	33	19	42.5	4	13	0.013
21	12.7	36	21	46.5	6	13	0.019
25	15.8	42	25	54.5	8	13	0.032
29	19.0	48	28	62.5	12	13	0.054
33	22.2	54	32	70.5	15	13	0.085
37	25.4	60	36	78.5	22	15	0.125
43	28.5	66	37	87.5	28	15	0.185
47	31.7	72	41	95.5	35	15	0.260
51	34.9	78	45	103.5	41	15	0.340
55	38.1	84	48	111.5	51	15	0.435
61	42.8	94	55	124.5	58	15	0.590
71	50.8	110	66	145.5	80	15	1.060

Mating materials:
Stainless steel on PTFE
Maintenance-free

Stainless steel
copper alloys free
 DIN ISO 12240-4
 series K

Inner ring: Stainless steel, hardened, ground and polished.

Outer ring: Stainless steel lined with an antifriction film, consisting of PTFE, outer diameter ground.

Housing: Stainless steel. The spherical bearing is pressed into the housing and caulked at both sides.

Female thread

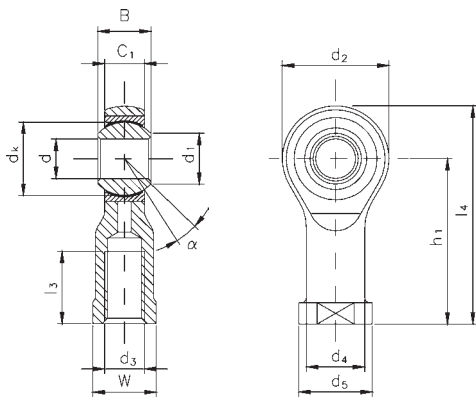

Designation		d	d ₃	B	C ₁	d ₁
Righthand thread	Lefthand thread	mm	mm	mm	mm	mm
KI 5-DNRBF	KIL 5-DNRBF	5	M5	8	6.00	7.7
KI 6-DNRBF	KIL 6-DNRBF	6	M6	9	6.75	8.9
KI 8-DNRBF	KIL 8-DNRBF	8	M8	12	9.00	10.3
KI 10-DNRBF	KIL 10-DNRBF	10	M10	14	10.50	12.9
KI 12-DNRBF	KIL 12-DNRBF	12	M12	16	12.00	15.4
KI 14-DNRBF	KIL 14-DNRBF	14	M14	19	13.50	16.8
KI 16-DNRBF	KIL 16-DNRBF	16	M16	21	15.00	19.3
KI 18-DNRBF	KIL 18-DNRBF	18	M18x1.5	23	16.50	21.8
KI 20-DNRBF	KIL 20-DNRBF	20	M20x1.5	25	18.00	24.3
KI 22-DNRBF	KIL 22-DNRBF	22	M22x1.5	28	20.00	25.8
KI 25-DNRBF	KIL 25-DNRBF	25	M24x2	31	22.00	29.5
KI 30-DNRBF	KIL 30-DNRBF	30	M30x2	37	25.00	34.8

Male thread

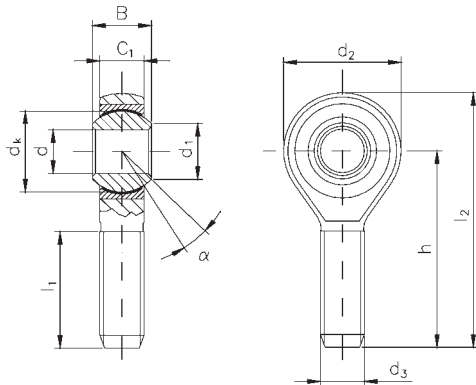

Designation		d	d ₃	B	C ₁	d ₁
Righthand thread	Lefthand thread	mm	mm	mm	mm	mm
KA 5-DNRBF	KAL 5-DNRBF	5	M5	8	6.00	7.7
KA 6-DNRBF	KAL 6-DNRBF	6	M6	9	6.75	8.9
KA 8-DNRBF	KAL 8-DNRBF	8	M8	12	9.00	10.3
KA 10-DNRBF	KAL 10-DNRBF	10	M10	14	10.50	12.9
KA 12-DNRBF	KAL 12-DNRBF	12	M12	16	12.00	15.4
KA 14-DNRBF	KAL 14-DNRBF	14	M14	19	13.50	16.8
KA 16-DNRBF	KAL 16-DNRBF	16	M16	21	15.00	19.3
KA 18-DNRBF	KAL 18-DNRBF	18	M18x1.5	23	16.50	21.8
KA 20-DNRBF	KAL 20-DNRBF	20	M20x1.5	25	18.00	24.3
KA 22-DNRBF	KAL 22-DNRBF	22	M22x1.5	28	20.00	25.8
KA 25-DNRBF	KAL 25-DNRBF	25	M24x2	31	22.00	29.5
KA 30-DNRBF	KAL 30-DNRBF	30	M30x2	37	25.00	34.8

Sizes 18 and 22 only on request.



Special versions: are available on request

d ₂ max. mm	d ₄ ≈ mm	d ₅ mm	dk mm	h ₁ mm	l ₃ min. mm	l ₄ ≈ mm	W mm	Load rating static C ₀ kN	Tilt angle α°	Weight kg
19	9.0	11	11.1	27	8	36.5	9	6	13	0.017
21	10.0	13	12.7	30	9	40.5	11	7	13	0.025
25	12.5	16	15.8	36	12	48.5	14	10	13	0.043
29	15.0	19	19.0	43	15	57.5	17	13	13	0.072
33	17.5	22	22.2	50	18	66.5	19	15	13	0.107
37	20.0	25	25.4	57	21	75.5	22	22	15	0.160
43	22.0	27	28.5	64	24	85.5	22	28	15	0.210
47	25.0	31	31.7	71	27	94.5	27	35	15	0.295
51	27.5	34	34.9	77	30	102.5	30	41	15	0.380
55	30.0	37	38.1	84	33	111.5	32	51	15	0.490
61	33.5	42	42.8	94	36	124.5	36	58	15	0.650
71	40.0	50	50.8	110	45	145.5	41	80	15	1.150

d ₂ max. mm	dk mm	h mm	l ₁ min. mm	l ₂ ≈ mm	Load rating static C ₀ kN	Tilt angle α°	Weight kg
19	11.1	33	19	42.5	4	13	0.013
21	12.7	36	21	46.5	6	13	0.019
25	15.8	42	25	54.5	8	13	0.032
29	19.0	48	28	62.5	12	13	0.054
33	22.2	54	32	70.5	15	13	0.085
37	25.4	60	36	78.5	22	15	0.125
43	28.5	66	37	87.5	28	15	0.185
47	31.7	72	41	95.5	35	15	0.260
51	34.9	78	45	103.5	41	15	0.340
55	38.1	84	48	111.5	51	15	0.435
61	42.8	94	55	124.5	58	15	0.590
71	50.8	110	66	145.5	80	15	1.060

Mating materials:
Steel on high-duty bronze
Maintenance required

Pneumatic
 Special version for
 pneumatic cylinder

- Inner ring:** Antifriction bearing steel, hardened, ground and polished.
- Outer ring:** Sliding face made of high-duty bronze. Lubricant is distributed via the lubricating groove in the outer ring.
- Housing:** Sizes 5 to 12 free-cutting steel, sizes 16 to 50 tempering steel (standardised), all sizes galvanized and chromatised. The spherical bearing is pressed into the housing and caulked at both sides.
- Lubrication nipple:** Size 5 without lubricating nipple, sizes 6 to 50 lubricating nipple DIN 3405, shape D, further lubricating nipple shapes available on request.

Female thread

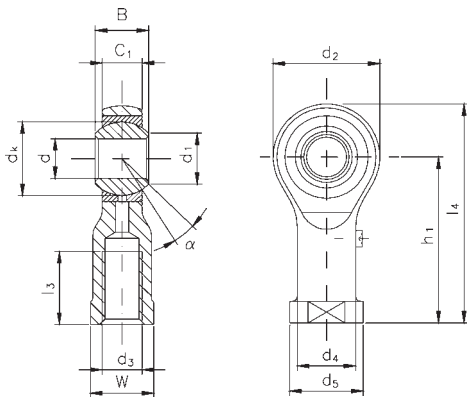

Designation	d	d ₃	B	C ₁	d ₁ ≈
Righthand thread	mm	mm	mm	mm	mm
KI 5-M4	5	M4	8	6.00	7.7
KI 6	6	M6	9	6.75	8.9
KI 8	8	M8	12	9.00	10.3
KI 10-M10x1.25	10	M10x1.25	14	10.50	12.9
KI 12-M12x1.25	12	M12x1.25	16	12.00	15.4
KI 16-M16x1.5	16	M16x1.5	21	15.00	19.3
KI 20	20	M20x1.5	25	18.00	24.3
KI 25	25	M24x2	31	22.00	29.5
KI 30-M27x2	30	M27x2	37	25.00	34.8
KI 35	35	M36x2	43	28.00	37.7
KI 40	40	M42x2	49	33.00	45.2
KI 50	50	M48x2	60	45.00	56.6

Special versions:

- **Version -V:**
as standard, but housing heat-treated,
for static load capacity see **-V** load rating stat **C0**

Further versions are available on request. E.g.:

- Housing crack-tested
- Sliding face of inner ring hard chromium plated
- Special surface coating of housing

d ₂ max.	d ₄ ≈	d ₅	dk	h ₁	l ₃ min.	l ₄ ≈	W	Load ratings static C ₀		Tilt angle	Weight
								Standard	-V		
mm	mm	mm	mm	mm	mm	mm	mm	kN	kN	α°	kg
19	9.0	11	11.1	27	8	36.5	9	6	•	13	0.016
21	10.0	13	12.7	30	9	40.5	11	7	•	13	0.025
25	12.5	16	15.8	36	12	48.5	14	12	16	13	0.043
29	15.0	19	19.0	43	15	57.5	17	15	19	13	0.072
33	17.5	22	22.2	50	18	66.5	19	23	25	13	0.107
43	22.0	27	28.5	64	24	85.5	22	34	36	15	0.210
51	27.5	34	34.9	77	30	102.5	30	42	50	15	0.380
61	33.5	42	42.8	94	36	124.5	36	60	78	15	0.650
70	40.0	50	50.8	110	45	145.5	41	82	107	15	1.150
81	46.0	58	57.1	125	56	165.5	50	96	•	16	1.600
91	53.0	65	66.6	142	60	187.5	55	145	•	17	2.400
117	65.0	75	82.5	160	65	218.5	65	209	•	12	5.000

Mating materials:
Steel on PTFE
Maintenance-free

Pneumatic
 Special version for
 pneumatic cylinder

Inner ring: Antifriction bearing steel, hardened, ground and polished.

Outer ring: Steel lined with an antifriction film, consisting of PTFE, outer diameter ground.

Housing: Sizes 5 to 12 free-cutting steel, sizes 16 to 50 tempering steel (standardised), all sizes galvanized and chromatised. The spherical bearing is pressed into the housing and caulked at both sides.

Female thread

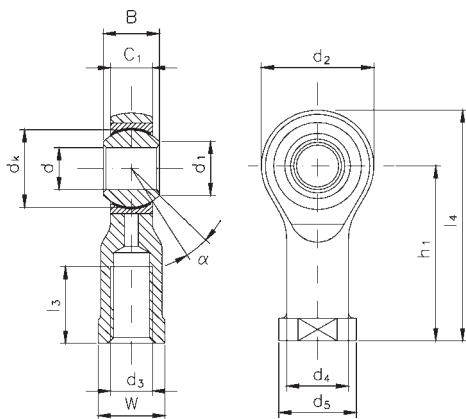

Designation	d	d ₃	B	C ₁	d ₁ ≈
Righthand thread	mm	mm	mm	mm	mm
KI 5-DM4	5	M4	8	6.00	7.7
KI 6-D	6	M6	9	6.75	8.9
KI 8-D	8	M8	12	9.00	10.3
KI 10-DM10x1.25	10	M10x1.25	14	10.50	12.9
KI 12-DM12x1.25	12	M12x1.25	16	12.00	15.4
KI 16-DM16x1.5	16	M16x1.5	21	15.00	19.3
KI 20-D	20	M20x1.5	25	18.00	24.3
KI 25-D	25	M24x2	31	22.00	29.5
KI 30-DM27x2	30	M27x2	37	25.00	34.8
KI 35-D	35	M36x2	43	28.00	37.7
KI 40-D	40	M42x2	49	33.00	45.2
KI 50-D	50	M48x2	60	45.00	56.6

Special versions:

- **Version -DV:**
as standard, but housing heat-treated,
for static load capacity see **-V** load rating stat **C0**

Further versions are available on request. E.g.:

- Housing crack-tested
- Sliding face of inner ring hard chromium plated
- Special surface coating of housing

d ₂ max.	d ₄ ≈	d ₅	dk	h ₁	l ₃ min.	l ₄ ≈	W	Load rating static C ₀		Tilt angle	Weight
								Standard	-V		
mm	mm	mm	mm	mm	mm	mm	mm	kN	kN	α°	kg
19	9.0	11	11.1	27	8	36.5	9	6	•	13	0.016
21	10.0	13	12.7	30	9	40.5	11	7	•	13	0.025
25	12.5	16	15.8	36	12	48.5	14	12	16	13	0.043
29	15.0	19	19.0	43	15	57.5	17	15	19	13	0.072
33	17.5	22	22.2	50	18	66.5	19	23	25	13	0.107
43	22.0	27	28.5	64	24	85.5	22	34	36	15	0.210
51	27.5	34	34.9	77	30	102.5	30	42	50	15	0.380
61	33.5	42	42.8	94	36	124.5	36	60	78	15	0.650
70	40.0	50	50.8	110	45	145.5	41	82	107	15	1.150
81	46.0	58	57.1	125	56	165.5	50	96	•	16	1.600
91	53.0	65	66.6	142	60	187.5	55	132	•	17	2.400
117	65.0	75	82.5	160	65	218.5	65	209	•	12	5.000

Mating materials:
Stainless steel on high-duty bronze
Maintenance required

Pneumatic stainless steel
 Special version for
 pneumatic cylinder

- Inner ring:** Stainless steel, hardened, ground and polished.
- Outer ring:** Swaged around the inner ring, sliding face made of high-duty bronze. Lubricant is distributed via the lubricating groove in the outer ring.
- Housing:** Stainless steel. The spherical bearing is pressed into the housing and caulked at both sides.
- Lubrication nipple:** Size 5 without lubricating nipple, sizes 6 to 50 lubricating nipple DIN 3405, shape D, further lubricating nipple shapes on request.

Female thread

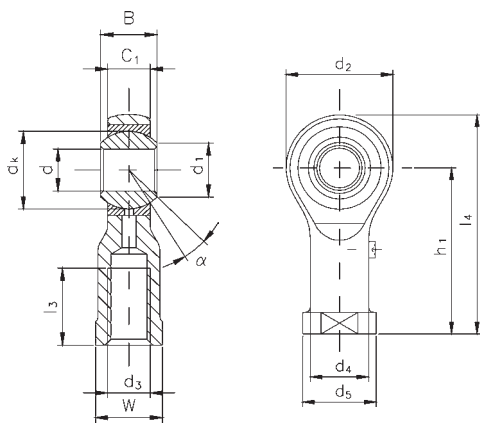

Designation	d	d ₃	B	C ₁	d ₁
Righthand thread	mm	mm	mm	mm	mm
KI 5-NRM4	5	M4	8	6.00	7.7
KI 6-NR	6	M6	9	6.75	8.9
KI 8-NR	8	M8	12	9.00	10.3
KI 10-NRM10x1.25	10	M10x1.25	14	10.50	12.9
KI 12-NRM12x1.25	12	M12x1.25	16	12.00	15.4
KI 16-NRM16x1.5	16	M16x1.5	21	15.00	19.3
KI 20-NR	20	M20x1.5	25	18.00	24.3
KI 25-NR	25	M24x2	31	22.00	29.5
KI 30-NRM27x2	30	M27x2	37	25.00	34.8

Special versions:
- Version -R:

as standard, but inner ring made of 100Cr6 hard chromium plated at sliding surface.

Further versions are available on request

d_2 max. mm	d_4 ≈ mm	d_5 mm	dk mm	h_1 mm	l_3 min. mm	l_4 ≈ mm	W mm	Load rating static C_0 kN	Tilt angle α°	Weight kg
19	9.0	11	11.1	27	8	36.5	9	6	13	0.016
21	10.0	13	12.7	30	9	40.5	11	7	13	0.025
25	12.5	16	15.8	36	12	48.5	14	10	13	0.043
29	15.0	19	19.0	43	15	57.5	17	13	13	0.072
33	17.5	22	22.2	50	18	66.5	19	15	13	0.107
43	22.0	27	28.5	64	24	85.5	22	28	15	0.210
51	27.5	34	34.9	77	30	102.5	30	41	15	0.380
61	33.5	42	42.8	94	36	124.5	36	58	15	0.650
70	40.0	50	50.8	110	45	145.5	41	80	15	1.150

Mating materials:
Stainless steel on PTFE
Maintenance-free

Pneumatic stainless steel
 Special version for
 pneumatic cylinder

- Inner ring:** Stainless steel, hardened, ground and polished.
- Outer ring:** Brass lined with an antifriction film, consisting of PTFE, outer diameter ground.
- Housing:** Stainless steel. The spherical bearing is pressed into the housing and caulked at both sides.

Female thread

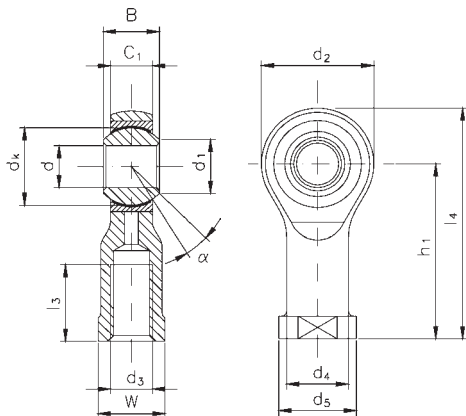

Designation	d	d ₃	B	C ₁	d ₁ ≈
Righthand thread	mm	mm	mm	mm	mm
KI 5-DNRM4	5	M4	8	6.00	7.7
KI 6-DNR	6	M6	9	6.75	8.9
KI 8-DNR	8	M8	12	9.00	10.3
KI 10-DNRM10x1.25	10	M10x1.25	14	10.50	12.9
KI 12-DNRM12x1.25	12	M12x1.25	16	12.00	15.4
KI 16-DNRM16x1.5	16	M16x1.5	21	15.00	19.3
KI 20-DNR	20	M20x1.5	25	18.00	24.3
KI 25-DNR	25	M24x2	31	22.00	29.5
KI 30-DNRM27x2	30	M27x2	37	25.00	34.8



Special versions:

- Version -DR:

as standard, but inner ring made of 100Cr6 hard chromium plated at sliding surface

Further versions are available on request

d ₂ max. mm	d ₄ ≈ mm	d ₅ mm	dk mm	h ₁ mm	l ₃ min. mm	l ₄ ≈ mm	W mm	Load rating static C ₀ kN	Tilt angle α°	Weight kg
19	9.0	11	11.1	27	8	36.5	9	6	13	0.016
21	10.0	13	12.7	30	9	40.5	11	7	13	0.025
25	12.5	16	15.8	36	12	48.5	14	10	13	0.043
29	15.0	19	19.0	43	15	57.5	17	13	13	0.072
33	17.5	22	22.2	50	18	66.5	19	15	13	0.107
43	22.0	27	28.5	64	24	85.5	22	28	15	0.210
51	27.5	34	34.9	77	30	102.5	30	41	15	0.380
61	33.5	42	42.8	94	36	124.5	36	58	15	0.650
70	40.0	50	50.8	110	45	145.5	41	80	15	1.150

Mating materials:
Stainless steel on PTFE
Maintenance-free

**Pneumatic stainless steel
copper alloys free**
Special version for
pneumatic cylinder

Inner ring: Stainless steel, hardened, ground and polished.

Outer ring: Stainless steel lined with an antifriction film, consisting of PTFE, cold formed around inner ring, outer diameter ground.

Housing: Stainless steel. The spherical bearing is pressed into the housing and caulked at both sides.

Female thread

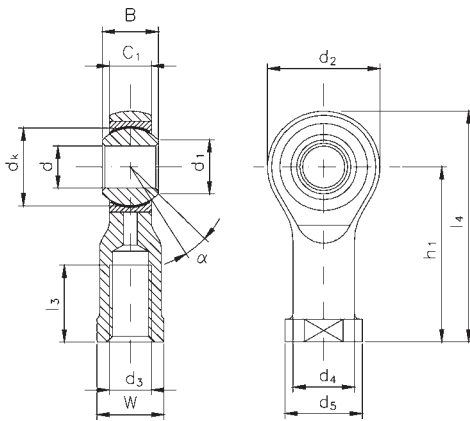

Designation	d	d ₃	B	C ₁	d ₁
Righthand thread	mm	mm	mm	mm	≈ mm
KI 5-DNRBFM4	5	M4	8	6.00	7.7
KI 6-DNRBF	6	M6	9	6.75	8.9
KI 8-DNRBF	8	M8	12	9.00	10.3
KI 10-DNRBFM10x1.25	10	M10x1.25	14	10.50	12.9
KI 12-DNRBFM12x1.25	12	M12x1.25	16	12.00	15.4
KI 16-DNRBFM16x1.5	16	M16x1.5	21	15.00	19.3
KI 20-DNRBF	20	M20x1.5	25	18.00	24.3
KI 25-DNRBF	25	M24x2	31	22.00	29.5
KI 30-DNRBFM27x2	30	M27x2	37	25.00	34.8



Special versions: available on request

d ₂ max. mm	d ₄ ≈ mm	d ₅ mm	dk mm	h ₁ mm	l ₃ min. mm	l ₄ ≈ mm	W mm	Load rating static C ₀ kN	Tilt angle α°	Weight kg
19	9.0	11	11.1	27	8	36.5	9	6	13	0.016
21	10.0	13	12.7	30	9	40.5	11	7	13	0.025
25	12.5	16	15.8	36	12	48.5	14	10	13	0.043
29	15.0	19	19.0	43	15	57.5	17	13	13	0.072
33	17.5	22	22.2	50	18	66.5	19	15	13	0.107
43	22.0	27	28.5	64	24	85.5	22	28	15	0.210
51	27.5	34	34.9	77	30	102.5	30	41	15	0.380
61	33.5	42	42.8	94	36	124.5	36	58	15	0.650
70	40.0	50	50.8	110	45	145.5	41	80	15	1.150

Mating materials:
Steel on steel
Maintenance required

RS
 Special version
 adjustable clearance
 RS sealing

available on request

- Inner ring:** Antifriction bearing steel, hardened, ground and polished.
- Outer ring:** Made of heat-treated steel. Lubricant is distributed via the lubrication groove in the outer ring.
- Rubber bellows:** Synthetic rubber.
- Housing:** Sizes 8 to 12 free-cutting steel, sizes 14 to 30 tempering steel (standardised), all sizes galvanized and chromatised.
- Lubricating nipple:** DIN 3405, shape D, further lubricating nipple shapes available on request.
- Tolerances:** To DIN ISO 12240-4, schedule K, except: $d = H8$, $B = +0.3$
- Note:** With these rod ends, it is important to ensure that the tilt angle specified in the table is not exceeded, either while mounting or during operation, otherwise the rubber bellows may be damaged. Replacement for previous 2RS-version. Available on request.

Female thread

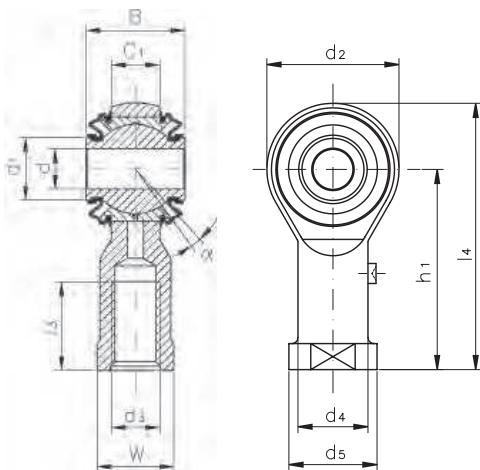

Designation		d	d ₃	B	C ₁	d ₁
Righthand thread	Lefthand thread	mm	mm	mm	mm	mm
KI 8-RS	KIL 8-RS	6	M8	19	9.0	11.50
KI 10-RS	KIL 10-RS	8	M10	21	10.5	13.50
KI 12-RS	KIL 12-RS	10	M12	23	12.0	15.50
KI 14-RS	KIL 14-RS	12	M14	26	13.5	17.50
KI 16-RS	KIL 16-RS	14	M16	28	15.0	19.50
KI 18-RS	KIL 18-RS	16	M18x1.5	30	16.5	22.00
KI 20-RS	KIL 20-RS	18	M20x1.5	32	18.0	24.50
KI 22-RS	KIL 22-RS	20	M22x1.5	35	20.0	26.50
KI 25-RS	KIL 25-RS	22	M24x2	38	22.0	29.50
KI 30-RS	KIL 30-RS	25	M30x2	44	25.0	35.00

Male thread

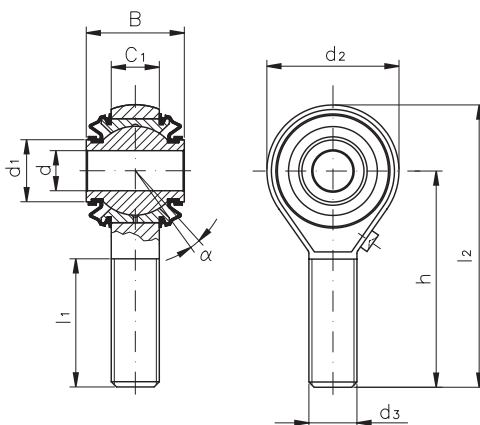

Designation		d	d ₃	B	C ₁	d ₁
Righthand thread	Lefthand thread	mm	mm	mm	mm	mm
KA 8-RS	KAL 8-RS	6	M8	19	9.0	11.50
KA 10-RS	KAL 10-RS	8	M10	21	10.5	13.50
KA 12-RS	KAL 12-RS	10	M12	23	12.0	15.50
KA 14-RS	KAL 14-RS	12	M14	26	13.5	17.50
KA 16-RS	KAL 16-RS	14	M16	28	15.0	19.50
KA 18-RS	KAL 18-RS	16	M18x1.5	30	16.5	22.00
KA 20-RS	KAL 20-RS	18	M20x1.5	32	18.0	24.50
KA 22-RS	KAL 22-RS	20	M22x1.5	35	20.0	26.50
KA 25-RS	KAL 25-RS	22	M24x2	38	22.0	29.50
KA 30-RS	KAL 30-RS	25	M30x2	44	25.0	35.00

Special versions:

- Mating materials steel on high-duty bronze.
 - Mating materials steel on steel with anti-friction coating.
- Further versions are available on request.

d ₂ max. mm	d ₄ mm	d ₅ mm	h ₁ mm	l ₃ min. mm	l ₄ ≈ mm	W mm	Load rating static C ₀ kN	Tilt angle α°	Weight kg
25	12.5	16	36	12	48.5	14	12	9	0.066
29	15.0	19	43	15	57.5	17	15	9	0.118
33	17.5	22	50	18	66.5	19	23	9	0.162
37	20.0	25	57	21	75.5	22	24	10	0.235
43	22.0	27	64	24	85.5	22	34	10	0.285
47	25.0	31	71	27	94.5	27	39	10	0.385
51	27.5	34	77	30	102.5	30	42	10	0.500
55	30.0	37	84	33	111.5	32	54	10	0.615
61	33.5	42	94	36	124.5	36	60	10	0.800
71	40.0	50	110	45	145.5	41	82	12	1.210

d ₂ max. mm	h mm	l ₁ min. mm	l ₂ ≈ mm	Load rating static C ₀ kN	Tilt angle α°	Weight kg
25	42	25	54.5	8	9	0.055
29	48	28	62.5	13	9	0.100
33	54	32	70.5	21	9	0.140
37	60	36	78.5	22	10	0.200
43	66	37	87.5	33	10	0.260
47	72	41	95.5	39	10	0.350
51	78	45	103.5	42	10	0.460
55	84	48	111.5	54	10	0.560
61	94	55	124.5	60	10	0.740
71	110	66	145.5	82	12	1.120

Mating materials:
Steel on PTFE
Maintenance-free

RS Special version RS sealing

available on request

- Inner ring:** Antifriction bearing steel, hardened, ground and polished.
- Outer ring:** Steel lined with an antifriction film, consisting PTFE.
- Rubber bellows:** Synthetic rubber.
- Housing:** Sizes 8 to 12 free-cutting steel, sizes 14 to 30 tempering steel (standardised), all sizes galvanized and chromatised.
- Tolerances:** Acc. To DIN ISO 12240-4, schedule K, except: $d = H8$, $B = +0.3$
- Note:** With these rod ends, it is important to ensure that the tilt angle specified in the table is not exceeded, either while mounting or during operation, otherwise the rubber bellows may be damaged. Replacement for previous 2RS-version. Available on request.

Female thread

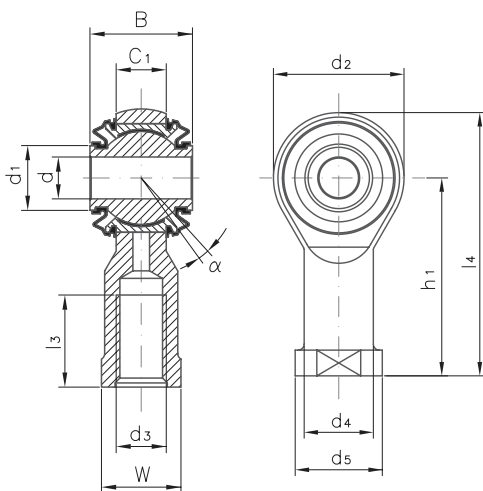

Designation		d	d ₃	B	C ₁	d ₁
Righthand thread	Lefthand thread	mm	mm	mm	mm	mm
KI 8-DRS	KIL 8-DRS	6	M8	19	9.0	11.5
KI 10-DRS	KIL 10-DRS	8	M10	21	10.5	13.5
KI 12-DRS	KIL 12-DRS	10	M12	23	12.0	15.5
KI 14-DRS	KIL 14-DRS	12	M14	26	13.5	17.5
KI 16-DRS	KIL 16-DRS	14	M16	28	15.0	19.5
KI 18-DRS	KIL 18-DRS	16	M18x1.5	30	16.5	22.0
KI 20-DRS	KIL 20-DRS	18	M20x1.5	32	18.0	24.5
KI 22-DRS	KIL 22-DRS	20	M22x1.5	35	20.0	26.5
KI 25-DRS	KIL 25-DRS	22	M24x2	38	22.0	29.5
KI 30-DRS	KIL 30-DRS	25	M30x2	44	25.0	35.0

Male thread

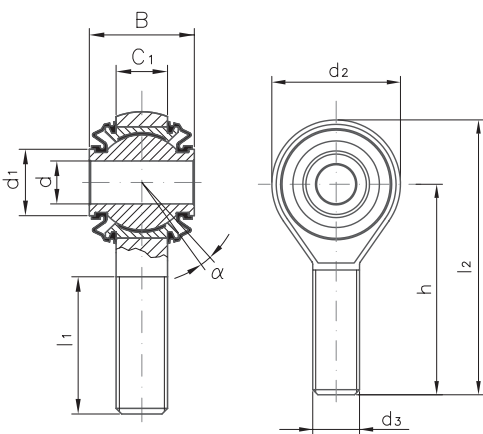

Designation		d	d ₃	B	C ₁	d ₁
Righthand thread	Lefthand thread	mm	mm	mm	mm	mm
KA 8-DRS	KAL 8-DRS	6	M8	19	9.0	11.5
KA 10-DRS	KAL 10-DRS	8	M10	21	10.5	13.5
KA 12-DRS	KAL 12-DRS	10	M12	23	12.0	15.5
KA 14-DRS	KAL 14-DRS	12	M14	26	13.5	17.5
KA 16-DRS	KAL 16-DRS	14	M16	28	15.0	19.5
KA 18-DRS	KAL 18-DRS	16	M18x1.5	30	16.5	22.0
KA 20-DRS	KAL 20-DRS	18	M20x1.5	32	18.0	24.5
KA 22-DRS	KAL 22-DRS	20	M22x1.5	35	20.0	26.5
KA 25-DRS	KAL 25-DRS	22	M24x2	38	22.0	29.5
KA 30-DRS	KAL 30-DRS	25	M30x2	44	25.0	35.0



Special versions: available on request

d ₂ max. mm	d ₄ mm	d ₅ mm	h ₁ mm	l ₃ min. mm	l ₄ ≈ mm	W mm	Load rating static C ₀ kN	Tilt angle α°	Weight kg
25	12.5	16	36	12	48.5	14	12	9	0.066
29	15.0	19	43	15	57.5	17	15	9	0.118
33	17.5	22	50	18	66.5	19	23	9	0.162
37	20.0	25	57	21	75.5	22	24	10	0.235
43	22.0	27	64	24	85.5	22	34	10	0.285
47	25.0	31	71	27	94.5	27	39	10	0.385
51	27.5	34	77	30	102.5	30	42	10	0.500
55	30.0	37	84	33	111.5	32	54	10	0.615
61	33.5	42	94	36	124.5	36	60	10	0.800
71	40.0	50	110	45	145.5	41	82	12	1.210

d ₂ max. mm	h mm	l ₁ min. mm	l ₂ ≈ mm	Load rating static C ₀ kN	Tilt angle α°	Weight kg
25	42	25	54.5	10	9	0.055
29	48	28	62.5	15	9	0.100
33	54	32	70.5	23	9	0.140
37	60	36	78.5	24	10	0.200
43	66	37	87.5	33	10	0.260
47	72	41	95.5	39	10	0.350
51	78	45	103.5	42	10	0.460
55	84	48	111.5	54	10	0.560
61	94	55	124.5	60	10	0.740
71	110	66	145.5	82	12	1.120

Mating materials:
Steel on high-duty bronze
Maintenance required

2RS version
Special version
2RS sealing

- Inner ring:** Antifriction bearing steel, hardened, ground and polished.
- Bearing shells:** Both shells made of heavy duty bronze have a male thread and are screwed into the housing together with the inner ring, secured with the rubber belows.
- Rubber belows:** Synthetic rubber with vulcanised brass slipring and steel locknut.
- Housing:** Sizes 8 to 12 free-cutting steel, sizes 14 to 30 tempering steel (standardised), all sizes galvanised and chromatised.
- Bushings:** Tempering steel, hardened, bore and outside diameter ground, pressed into the inner ring. They are only used as intake of the brass abrasive rings of the rubber belows. Due to their low thickness they are not decicated to transmit radial and axial forces into the spherical bearing.
- Lubricating nipple:** DIN 3405 shape D, further lubricating nipple shapes available on request.
- Tolerances:** To DIN ISO 12240-4, schedule K, except: $d = H10$, $B = + - 0,3$

Female thread

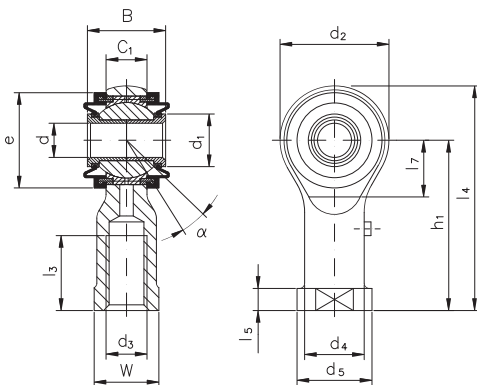

Designation		d	d ₃	B	C ₁
Right-hand thread	Left-hand thread	mm			
KI 8-STK2RS	KIL 8-STK2RS	6	M8	19	9,0
KI 10-STK2RS	KIL 10-STK2RS	8	M10	21	10,5
KI 12-STK2RS	KIL 12-STK2RS	10	M12	23	12,0
KI 14-STK2RS	KIL 14-STK2RS	12	M14	26	13,5
KI 16-STK2RS	KIL 16-STK2RS	14	M16	28	15,0
KI 18-STK2RS	KIL 18-STK2RS	16	M18x1,5	30	16,5
KI 20-STK2RS	KIL 20-STK2RS	18	M20x1,5	32	18,0
KI 22-STK2RS	KIL 22-STK2RS	20	M22x1,5	35	20,0
KI 25-STK2RS	KIL 25-STK2RS	22	M24x2	38	22,0
KI 30-STK2RS	KIL 30-STK2RS	25	M30x2	44	25,0

Male thread

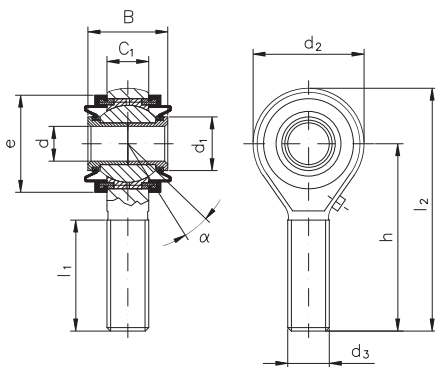

Designation		d	d ₃	B	C ₁
Right-hand thread	Left-hand thread	mm			
KA 8-STK2RS	KAL 8-STK2RS	6	M8	19	9,0
KA 10-STK2RS	KAL 10-STK2RS	8	M10	21	10,5
KA 12-STK2RS	KAL 12-STK2RS	10	M12	23	12,0
KA 14-STK2RS	KAL 14-STK2RS	12	M14	26	13,5
KA 16-STK2RS	KAL 16-STK2RS	14	M16	28	15,0
KA 18-STK2RS	KAL 18-STK2RS	16	M18x1,5	30	16,5
KA 20-STK2RS	KAL 20-STK2RS	18	M20x1,5	32	18,0
KA 22-STK2RS	KAL 22-STK2RS	20	M22x1,5	35	20,0
KA 25-STK2RS	KAL 25-STK2RS	22	M24x2	38	22,0
KA 30-STK2RS	KAL 30-STK2RS	25	M30x2	44	25,0

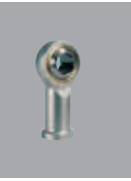

Note: With these rod ends, it is important to ensure that the tilt angle specified in the table is not exceeded, either while mounting or during operation, otherwise the rubber bellows may be damaged

Special versions: available on request.

d ₁	d ₂	d ₄	d ₅	e	h ₁	l ₃	l ₄ ≈	W	Load ratings stat C ₀ housing kN	Tilt angle α°	Weight kg
	max			≈		min					
10,5	25	12,5	16	20	36	12	48,5	14	12	9	0,066
13,0	29	15,0	19	24	43	15	57,5	17	15	9	0,118
15,5	33	17,5	22	28	50	18	66,5	19	23	9	0,162
17,0	37	20,0	25	30	57	21	75,5	22	24	10	0,235
19,5	43	22,0	27	34	64	24	85,5	22	34	10	0,285
22,0	47	25,0	31	37	71	27	94,5	27	39	10	0,385
24,5	51	27,5	34	40	77	30	102,5	30	42	10	0,500
26,0	55	30,0	37	44	84	33	111,5	32	54	10	0,615
29,5	61	33,5	42	50	94	36	124,5	36	60	10	0,800
35,0	71	40,0	50	58	110	45	145,5	41	82	12	1,210

d ₁	d ₂	e	h	l ₁	l ₂ ≈	Load ratings stat C ₀ housing kN	Tilt angle α°	Weight kg
	max	≈		min				
10,5	25	20	42	25	54,5	10	9	0,055
13,0	29	24	48	28	62,5	15	9	0,100
15,5	33	28	54	32	70,5	23	9	0,140
17,0	37	30	60	36	78,5	24	10	0,200
19,5	43	34	66	37	87,5	33	10	0,260
22,0	47	37	72	41	95,5	39	10	0,350
24,5	51	40	78	45	103,5	42	10	0,460
26,0	55	44	84	48	111,5	54	10	0,560
29,5	61	50	94	55	124,5	60	10	0,740
35,0	71	58	110	66	145,5	82	12	1,120

Mating materials:
Steel on PTFE
Maintenance-free

2RS version
Special version
2RS sealing

- Inner ring:** Antifriction bearing steel, hardened, ground and polished.
- Bearing shells:** Brass lined with an antifriction film, consisting PTFE, cold formed around inner ring, outside diameter with thread, screwed into housing and secured with the rubber bellows.
- Rubber bellows:** Synthetic rubber with vulcanised brass slipring and steel locknut.
- Housing:** Sizes 8 to 12 free-cutting steel, sizes 14 to 30 tempering steel (standardised), all sizes galvanised and chromatised.
- Bushings:** Tempering steel, hardened, bore and outside diameter ground, pressed into the inner ring. They are only used as intake of the brass abrasive rings of the rubber bellows. Due to their low thickness they are not decicated to transmit radial and axial forces into the spherical bearing.

Female thread

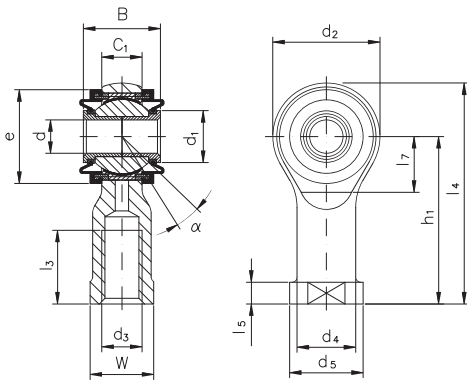

Designation		d	d ₃	B	C ₁
Right-hand thread	Left-hand thread	mm			
KI 8-D2RS	KIL 8-D2RS	6	M8	19	9,0
KI 10-D2RS	KIL 10-D2RS	8	M10	21	10,5
KI 12-D2RS	KIL 12-D2RS	10	M12	23	12,0
KI 14-D2RS	KIL 14-D2RS	12	M14	26	13,5
KI 16-D2RS	KIL 16-D2RS	14	M16	28	15,0
KI 18-D2RS	KIL 18-D2RS	16	M18x1,5	30	16,5
KI 20-D2RS	KIL 20-D2RS	18	M20x1,5	32	18,0
KI 22-D2RS	KIL 22-D2RS	20	M22x1,5	35	20,0
KI 25-D2RS	KIL 25-D2RS	22	M24x2	38	22,0
KI 30-D2RS	KIL 30-D2RS	25	M30x2	44	25,0

Male thread

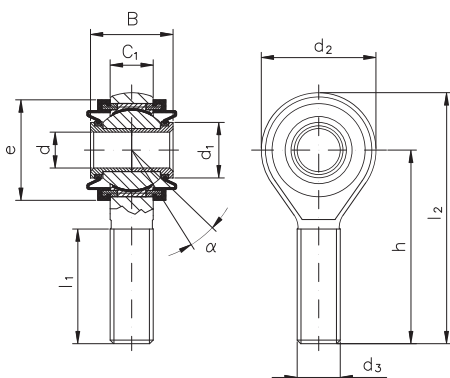

Designation		d	d ₃	B	C ₁
Right-hand thread	Left-hand thread	mm			
KA 8-D2RS	KAL 8-D2RS	6	M8	19	9,0
KA 10-D2RS	KAL 10-D2RS	8	M10	21	10,5
KA 12-D2RS	KAL 12-D2RS	10	M12	23	12,0
KA 14-D2RS	KAL 14-D2RS	12	M14	26	13,5
KA 16-D2RS	KAL 16-D2RS	14	M16	28	15,0
KA 18-D2RS	KAL 18-D2RS	16	M18x1,5	30	16,5
KA 20-D2RS	KAL 20-D2RS	18	M20x1,5	32	18,0
KA 22-D2RS	KAL 22-D2RS	20	M22x1,5	35	20,0
KA 25-D2RS	KAL 25-D2RS	22	M24x2	38	22,0
KA 30-D2RS	KAL 30-D2RS	25	M30x2	44	25,0

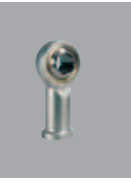

Tolerances: Acc. to DIN ISO 12240-4, schedule K, except: $d = H10$, $B = \pm 0,3$

Note: With these rod ends, it is important to ensure that the tilt angle specified in the table is not exceeded, either while mounting or during operation, otherwise the rubber bellows may be damaged.

Special versions: available on request.

d_1	d_2	d_4	d_5	e	h_1	l_3	l_4 ≈	W	Load ratings stat C_0 housing kN	Tilt angle α°	Weight kg
	max			≈		min					
10,5	25	12,5	16	20	36	12	48,5	14	12	9	0,066
13,0	29	15,0	19	24	43	15	57,5	17	15	9	0,118
15,5	33	17,5	22	28	50	18	66,5	19	23	9	0,162
17,0	37	20,0	25	30	57	21	75,5	22	24	10	0,235
19,5	43	22,0	27	34	64	24	85,5	22	34	10	0,285
22,0	47	25,0	31	37	71	27	94,5	27	39	10	0,385
24,5	51	27,5	34	40	77	30	102,5	30	42	10	0,500
26,0	55	30,0	37	44	84	33	111,5	32	54	10	0,615
29,5	61	33,5	42	50	94	36	124,5	36	60	10	0,800
35,0	71	40,0	50	58	110	45	145,5	41	82	12	1,210

d_1	d_2	e	h	l_1	l_2 ≈	Load ratings stat C_0 housing kN	Tilt angle α°	Weight kg
	max	≈		min				
10,5	25	20	42	25	54,5	10	9	0,055
13,0	29	24	48	28	62,5	15	9	0,100
15,5	33	28	54	32	70,5	23	9	0,140
17,0	37	30	60	36	78,5	24	10	0,200
19,5	43	34	66	37	87,5	33	10	0,260
22,0	47	37	72	41	95,5	39	10	0,350
24,5	51	40	78	45	103,5	42	10	0,460
26,0	55	44	84	48	111,5	54	10	0,560
29,5	61	50	94	55	124,5	60	10	0,740
35,0	71	58	110	66	145,5	82	12	1,120

Mating materials:
Steel on steel
Maintenance required

DO
 DIN ISO 12240-4
 dimension series E

Inner ring: Antifriction bearing steel, hardened, ground.

Outer ring: Antifriction bearing steel, hardened, ground. Outer ring is split for assembly of inner ring.

Housing: Made of steel, all sizes galvanized and chromatised. The spherical bearing is pressed into the housing and caulked at both sides.

Lubrication nipple: Sizes 6 to 15 without lubricating nipple, sizes 17 to 30 nipple DIN 3405, shape D, further lubricating nipple shapes on request.

Female thread

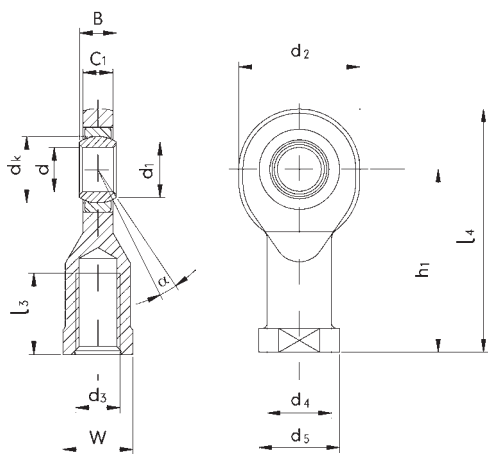

Designation		d	d ₃	B	C ₁	d ₁
Righthand thread	Lefthand thread	mm	mm	mm	max, mm	≈ mm
GIR 6-DO	GIL 6-DO	6	M6	6	4.5	8
GIR 8-DO	GIL 8-DO	8	M8	8	6.5	10
GIR 10-DO	GIL 10-DO	10	M10	9	7.5	13
GIR 12-DO	GIL 12-DO	12	M12	10	8.5	15
GIR 15-DO	GIL 15-DO	15	M14	12	10.5	18
GIR 17-DO	GIL 17-DO	17	M16	14	11.5	20
GIR 20-DO	GIL 20-DO	20	M20x1.5	16	13.5	24
GIR 25-DO	GIL 25-DO	25	M24x2	20	18.0	29
GIR 30-DO	GIL 30-DO	30	M30x2	22	20.0	34
GIR 35-DO	GIL 35-DO	35	M36x3	25	22.0	39
GIR 40-DO	GIL 40-DO	40	M39x3	28	24.0	45
GIR 50-DO	GIL 50-DO	50	M45x3	35	31.0	55
GIR 60-DO	GIL 60-DO	60	M52x3	44	39.0	66
GIR 70-DO	GIL 70-DO	70	M56x4	49	43.0	77
GIR 80-DO	GIL 80-DO	80	M64x4	55	48.0	88

Male thread

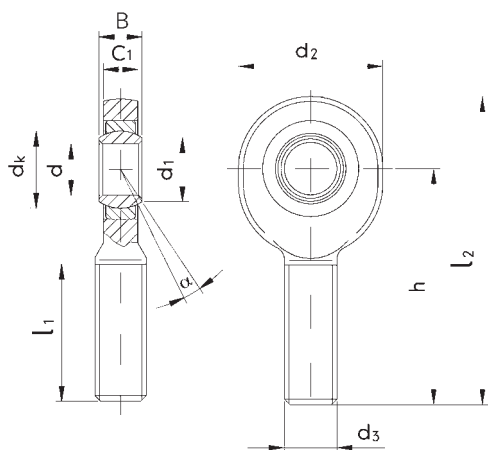

Designation		d	d ₃	B	C ₁	d ₁
Righthand thread	Lefthand thread	mm	mm	mm	max. mm	≈ mm
GAR 6-DO	GAL 6-DO	6	M6	6	4.5	8
GAR 8-DO	GAL 8-DO	8	M8	8	6.5	10
GAR 10-DO	GAL 10-DO	10	M10	9	7.5	13
GAR 12-DO	GAL 12-DO	12	M12	10	8.5	15
GAR 15-DO	GAL 15-DO	15	M14	12	10.5	18
GAR 17-DO	GAL 17-DO	17	M16	14	11.5	20
GAR 20-DO	GAL 20-DO	20	M20x1.5	16	13.5	24
GAR 25-DO	GAL 25-DO	25	M24x2	20	18.0	29
GAR 30-DO	GAL 30-DO	30	M30x2	22	20.0	34
GAR 35-DO	GAL 35-DO	35	M36x3	25	22.0	39
GAR 40-DO	GAL 40-DO	40	M39x3	28	24.0	45
GAR 50-DO	GAL 50-DO	50	M45x3	35	31.0	55
GAR 60-DO	GAL 60-DO	60	M52x3	44	39.0	66
GAR 70-DO	GAL 70-DO	70	M56x4	49	43.0	77
GAR 80-DO	GAL 80-DO	80	M64x4	55	48.0	88



Special versions: available on request

d ₂ max. mm	d ₄ ≈ mm	d ₅ max. mm	dk mm	h ₁ mm	l ₃ min. mm	l ₄ max. mm	W mm	Load rating static C ₀ kN	Tilt angle α°	Weight kg
22	11	14	10	30	11	43	11	8.1	13	0.021
25	13	17	13	36	15	50	13	12.9	15	0.039
30	16	20	16	43	15	60	16	17.6	12	0.061
35	19	23	18	50	18	69	18	24.5	10	0.096
41	22	27	22	61	21	83	21	36.0	8	0.162
47	25	31	25	67	24	92	27	45.0	10	0.233
54	28	36	29	77	30	106	30	60.0	9	0.324
65	35	44	35	94	36	128	36	83.0	7	0.625
75	42	52	40	110	45	149	46	110.0	6	0.976
84	47	60	47	125	60	169	55	146.0	6	1.520
94	52	67	53	142	65	191	60	180.0	7	2.060
114	62	77	66	160	68	219	70	290.0	6	3.570
137	70	90	80	175	70	246	80	450.0	6	5.630
162	80	100	92	200	80	284	85	610.0	6	8.330
182	95	112	105	230	85	324	95	750.0	6	13.040

d ₂ max. mm	dk mm	h mm	l ₁ min. mm	l ₂ max. mm	Load rating static C ₀ kN	Tilt angle α°	Weight kg
22	10	36	16	49	5.5	13	0.017
25	13	42	21	56	10.0	15	0.029
30	16	48	26	65	16.0	12	0.044
35	18	54	28	73	23.0	11	0.066
41	22	63	34	85	32.0	9	0.121
47	25	69	36	94	44.0	10	0.172
54	29	78	43	107	60.0	9	0.283
65	35	94	53	128	83.0	8	0.504
75	40	110	65	149	110.0	7	0.835
84	47	140	82	184	146.0	6	1.410
94	53	150	86	199	180.0	7	1.860
114	66	185	104	244	290.0	6	3.580
137	80	210	115	281	450.0	6	5.730
162	92	235	125	319	610.0	6	7.940
182	105	270	140	364	750.0	6	12.060

Mating materials:
Steel on PTFE
Maintenance-free

UK
DIN ISO 12240-4
dimension series E

Inner ring: Antifriction bearing steel, hardened, ground and polished, raceway hard chromium plated.

Outer ring: Free-cutting steel, lined with PTFE.

Housing: Made of steel, all sizes galvanized and chromatised. The spherical bearing is pressed into the housing and caulked at both sides.

Female thread

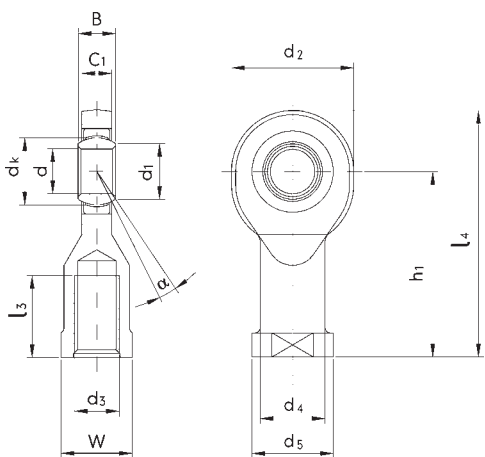

Designation		d	d ₃	B	C ₁ max.	d ₁ ≈
Righthand thread	Lefthand thread	mm	mm	mm	mm	mm
GIR 6-UK	GIL 6-UK	6	M6	6	4.5	8
GIR 8-UK	GIL 8-UK	8	M8	8	6.5	10
GIR 10-UK	GIL 10-UK	10	M10	9	7.5	13
GIR 12-UK	GIL 12-UK	12	M12	10	8.5	15
GIR 15-UK	GIL 15-UK	15	M14	12	10.5	18
GIR 15-UK2RS	GIL 15-UK2RS	15	M14	12	10.5	18
GIR 17-UK	GIL 17-UK	17	M16	14	11.5	20
GIR 17-UK2RS	GIL 17-UK2RS	17	M16	14	11.5	20
GIR 20-UK	GIL 20-UK	20	M20x1.5	16	13.5	24
GIR 20-UK2RS	GIL 20-UK2RS	20	M20x1.5	16	13.5	24
GIR 25-UK	GIL 25-UK	25	M24x2	20	18.0	29
GIR 25-UK2RS	GIL 25-UK2RS	25	M24x2	20	18.0	29
GIR 30-UK	GIL 30-UK	30	M30x2	22	20.0	34
GIR 30-UK2RS	GIL 30-UK2RS	30	M30x2	22	20.0	34
GIR 35-UK2RS	GIL 35-UK2RS	35	M36x3	25	22.0	39
GIR 40-UK2RS	GIL 40-UK2RS	40	M39x3	28	24.0	45
GIR 50-UK2RS	GIL 50-UK2RS	50	M45x3	35	31.0	55
GIR 60-UK2RS	GIL 60-UK2RS	60	M52x3	44	39.0	66
GIR 70-UK2RS	GIL 70-UK2RS	70	M56x4	49	43.0	77
GIR 80-UK2RS	GIL 80-UK2RS	80	M64x4	55	48.0	88

Male thread

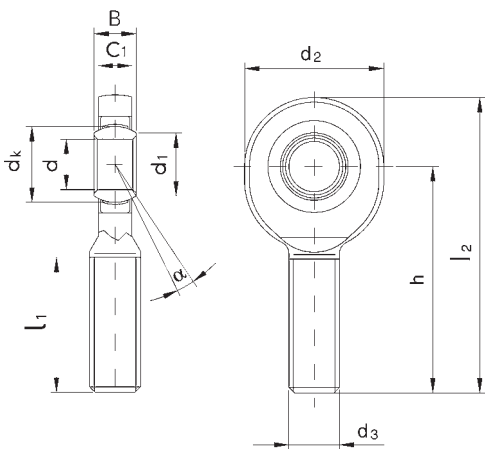

Designation		d	d ₃	B	C ₁ max.	d ₁ ≈
Righthand thread	Lefthand thread	mm	mm	mm	mm	mm
GAR 6-UK	GAL 6-UK	6	M6	6	4.5	8
GAR 8-UK	GAL 8-UK	8	M8	8	6.5	10
GAR 10-UK	GAL 10-UK	10	M10	9	7.5	13
GAR 12-UK	GAL 12-UK	12	M12	10	8.5	15
GAR 15-UK	GAL 15-UK	15	M14	12	10.5	18
GAR 15-UK2RS	GAL 15-UK2RS	15	M14	12	10.5	18
GAR 17-UK	GAL 17-UK	17	M16	14	11.5	20
GAR 17-UK2RS	GAL 17-UK2RS	17	M16	14	11.5	20
GAR 20-UK	GAL 20-UK	20	M20x1.5	16	13.5	24
GAR 20-UK2RS	GAL 20-UK2RS	20	M20x1.5	16	13.5	24
GAR 25-UK	GAL 25-UK	25	M24x2	20	18.0	29
GAR 25-UK2RS	GAL 25-UK2RS	25	M24x2	20	18.0	29
GAR 30-UK	GAL 30-UK	30	M30x2	22	20.0	34
GAR 30-UK2RS	GAL 30-UK2RS	30	M30x2	22	20.0	34
GAR 35-UK2RS	GAL 35-UK2RS	35	M36x3	25	22.0	39
GAR 40-UK2RS	GAL 40-UK2RS	40	M39x3	28	24.0	45
GAR 50-UK2RS	GAL 50-UK2RS	50	M45x3	35	31.0	55
GAR 60-UK2RS	GAL 60-UK2RS	60	M52x3	44	39.0	66
GAR 70-UK2RS	GAL 70-UK2RS	70	M56x4	49	43.0	77
GAR 80-UK2RS	GAL 80-UK2RS	80	M64x4	55	48.0	88



Special versions: available on request

d ₂ max. mm	d ₄ ≈ mm	d ₅ max. mm	dk mm	h ₁ mm	l ₃ min. mm	l ₄ max. mm	W mm	Load rating static C ₀ kN	Tilt angle α°	Weight kg
22	11	14	10	30	11	43	11	8.1	13	0.021
25	13	17	13	36	15	50	13	12.9	15	0.039
30	16	20	16	43	15	60	16	17.6	12	0.061
35	19	23	18	50	18	69	18	24.5	10	0.096
41	22	27	22	61	21	83	21	36.0	8	0.160
41	22	27	22	61	21	83	21	36.0	8	0.160
47	25	31	25	67	24	92	27	45.0	10	0.230
47	25	31	25	67	24	92	27	45.0	10	0.230
54	28	36	29	77	30	106	30	60.0	9	0.320
54	28	36	29	77	30	106	30	60.0	9	0.320
65	35	44	35	94	36	128	36	83.0	7	0.620
65	35	44	35	94	36	128	36	83.0	7	0.620
75	42	52	40	110	45	149	46	110.0	6	0.970
75	42	52	40	110	45	149	46	110.0	6	0.970
84	47	60	47	125	60	169	55	146.0	6	1.500
94	52	67	53	142	65	191	60	180.0	7	2.100
114	62	77	66	160	68	219	70	290.0	6	3.500
137	70	90	80	175	70	246	80	450.0	6	5.600
162	80	100	92	200	80	284	85	610.0	6	8.300
182	95	112	105	230	85	324	95	750.0	6	13.000

d ₂ max. mm	dk mm	h mm	l ₁ min. mm	l ₂ max. mm	Load rating static C ₀ kN	Tilt angle α°	Weight kg
22	10	36	16	49	5.5	13	0.017
25	13	42	21	56	10.0	15	0.029
30	16	48	26	65	16.0	12	0.044
35	18	54	28	73	23.0	10	0.066
41	22	63	34	85	32.0	8	0.120
41	22	63	34	85	32.0	8	0.120
47	25	69	36	94	44.0	10	0.170
47	25	69	36	94	44.0	10	0.170
54	29	78	43	107	60.0	9	0.280
54	29	78	43	107	60.0	9	0.280
65	35	94	53	128	83.0	7	0.510
65	35	94	53	128	83.0	7	0.510
75	40	110	65	149	110.0	6	0.840
75	40	110	65	149	110.0	6	0.840
84	47	140	82	184	146.0	6	1.400
94	53	150	86	199	180.0	7	1.800
114	66	185	104	244	290.0	6	3.600
137	80	210	115	281	450.0	6	5.700
162	92	235	125	319	610.0	6	7.900
182	105	270	140	364	750.0	6	12.000

