

ASKUBAL® Rod ends and spherical bearings

Mating materials:
Steel on heavy-duty bronze
Maintenance required

Type G
 DIN ISO 12240-1
 dimension series K

- Inner ring:** Antifriction bearing steel, hardened, ground and polished.
- Outer ring:** Outer diameter ground. Sliding face made of high-duty bronze. Lubricant is distributed via the lubricating groove in the outer ring.
- Lubrication:** The lubricant enters the lubricating groove through a cross hole in the outer ring.
- Special versions:** are available on request e.g.:
 - Sliding face of inner ring hard chromium plated.

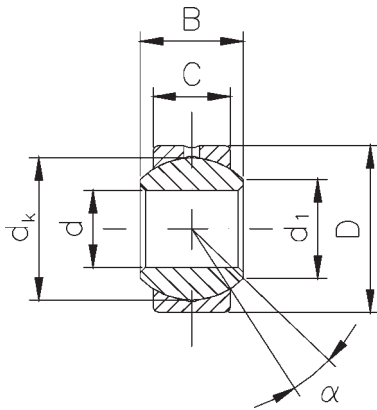

Designation	d	d ₁	B	C	D	dk	Load rating static C ₀	Tilt angle	Weight
	mm	mm	mm	mm	mm	mm	kN	α°	kg
G 3	3	5.1	6	4.50	10	7.9	8	13	0.004
G 5	5	7.7	8	6.00	13	11.1	15	13	0.007
G 6	6	8.9	9	6.75	16	12.7	19	13	0.010
G 8	8	10.3	12	9.00	19	15.8	31	13	0.016
G 10	10	12.9	14	10.50	22	19.0	43	13	0.031
G 12	12	15.4	16	12.00	26	22.2	58	13	0.065
G 14	14	16.8	19	13.50	28	25.4	74	15	0.090
G 16	16	19.3	21	15.00	32	28.5	92	15	0.100
G 18	18	21.8	23	16.50	35	31.7	112	15	0.125
G 20	20	24.3	25	18.00	40	34.9	135	15	0.180
G 22	22	25.8	28	20.00	42	38.1	164	15	0.210
G 25	25	29.5	31	22.00	47	42.8	203	15	0.295
G 30	30	34.8	37	25.00	55	50.8	273	15	0.425
G 35	35	37.7*	43	28.00*	62*	57.1	344	16	0.500
G 40	40	45.2*	49	33.00*	75*	66.6	473	17	0.900
G 50	50	56.6*	60	45.00	90	82.5	798	12	1.640

*) deviates from standard

Mating materials:
Steel on heavy-duty bronze
Maintenance required

Type S
Special version

- Inner ring:** Antifriction bearing steel, hardened, ground and polished.
- Outer ring:** Outer diameter ground. Sliding face made of high-duty bronze. Lubricant is distributed via the lubricating groove in the outer ring.
- Outer case:** Steel, outer diameter ground. Spherical bearing is pressed into the outer case and secured at both sides against axial movement. However the two outer rings should be axial supported at mounting.
- Lubrication:** The lubricant enters the lubricating groove through a cross hole in the outer case.
- Special versions:** are available on request e.g.:
 - Sliding face of inner ring hard chromium plated.
 - Outer case made of stainless steel.

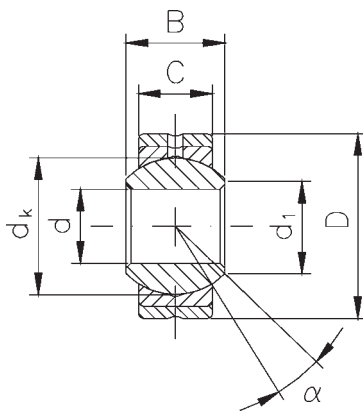

Designation	d	d ₁	B	C	D	dk	Load rating static C ₀	Tilt angle	Weight
	mm	mm	mm	mm	mm	mm	kN	α°	kg
S 3	3	5.1	6	4.50	12	7.9	8	13	0.005
S 5	5	7.7	8	6.00	16	11.1	15	13	0.009
S 6	6	8.9	9	6.75	18	12.7	19	13	0.013
S 8	8	10.3	12	9.00	22	15.8	31	13	0.024
S 10	10	12.9	14	10.50	26	19.0	43	13	0.040
S 12	12	15.4	16	12.00	30	22.2	58	13	0.080
S 14	14	16.8	19	13.50	34	25.4	74	15	0.100
S 16	16	19.3	21	15.00	38	28.5	92	15	0.130
S 18	18	21.8	23	16.50	42	31.7	112	15	0.170
S 20	20	24.3	25	18.00	46	34.9	135	15	0.230
S 22	22	25.8	28	20.00	50	38.1	164	15	0.280
S 25	25	29.5	31	22.00	56	42.8	203	15	0.390
S 30	30	34.8	37	25.00	66	50.8	273	15	0.610

Mating materials:
Steel on PTFE
Maintenance-free

Type G
 DIN ISO 12240-1
 dimension series K

Inner ring: Antifriction bearing steel, hardened, ground and polished.

Outer ring: Steel lined with an antifriction film, consisting of PTFE, outer diameter ground.

Special versions: are available on request e.g.:
 - Sliding face of inner ring hard chromium plated.

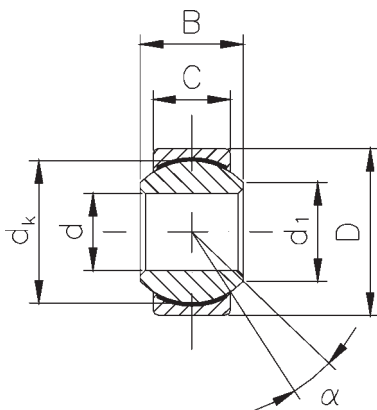

Designation	d	d ₁	B	C	D	dk	Load rating static C ₀	Tilt angle	Weight
	mm	mm	mm	mm	mm	mm	kN	α°	kg
G 5-D	5	7.7	8	6.00	13	11.1	14	13	0.007
G 6-D	6	8.9	9	6.75	16	12.7	18	13	0.010
G 8-D	8	10.3	12	9.00	19	15.8	30	13	0.016
G 10-D	10	12.9	14	10.50	22	19.0	42	13	0.031
G 12-D	12	15.4	16	12.00	26	22.2	56	13	0.065
G 14-D	14	16.8	19	13.50	28	25.4	72	15	0.090
G 16-D	16	19.3	21	15.00	32	28.5	90	15	0.100
G 18-D	18	21.8	23	16.50	35	31.7	110	15	0.125
G 20-D	20	24.3	25	18.00	40	34.9	132	15	0.180
G 22-D	22	25.8	28	20.00	42	38.1	160	15	0.210
G 25-D	25	29.5	31	22.00	47	42.8	198	15	0.295
G 30-D	30	34.8	37	25.00	55	50.8	267	15	0.425
G 35-D	35	37.7*	43	28.00*	62*	57.1	336	16	0.500
G 40-D	40	45.2*	49	33.00*	75*	66.6	462	17	0.900
G 50-D	50	56.6*	60	45.00	90	82.5	780	12	1.640

*) deviates from standard

Mating materials:
Steel on PTFE
Maintenance-free

Type S
Special version

- Inner ring:** Antifriction bearing steel, hardened, ground and polished.
- Outer ring:** Steel lined with an antifriction film, consisting of PTFE, outer diameter ground.
- Outer case:** Steel, outer diameter ground. Spherical bearing is pressed into the outer case and secured at both sides against axial movement.
- Special versions:** are available on request e.g.:
- Sliding face of inner ring hard chromium plated.
- Outer case made of stainless steel.

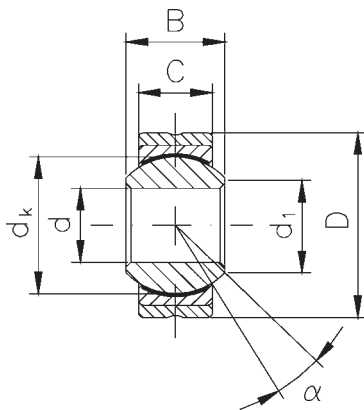

Designation	d	d ₁	B	C	D	d _k	Load rating static C ₀	Tilt angle	Weight
	mm	mm	mm	mm	mm	mm	kN	°	kg
S 5-D	5	7.7	8	6.00	16	11.1	14	13	0.009
S 6-D	6	8.9	9	6.75	18	12.7	18	13	0.013
S 8-D	8	10.3	12	9.00	22	15.8	30	13	0.024
S 10-D	10	12.9	14	10.50	26	19.0	42	13	0.040
S 12-D	12	15.4	16	12.00	30	22.2	56	13	0.080
S 14-D	14	16.8	19	13.50	34	25.4	72	15	0.110
S 16-D	16	19.3	21	15.00	38	28.5	90	15	0.130
S 18-D	18	21.8	23	16.50	42	31.7	110	15	0.170
S 20-D	20	24.3	25	18.00	46	34.9	132	15	0.230
S 22-D	22	25.8	28	20.00	50	38.1	160	15	0.280
S 25-D	25	29.5	31	22.00	56	42.8	198	15	0.390
S 30-D	30	34.8	37	25.00	66	50.8	267	15	0.610

Mating materials:
Stainless steel on
heavy-duty bronze
Maintenance required

Stainless steel
 Type G
 DIN ISO 12240-1
 dimension series K

- Inner ring:** Stainless steel, hardened, ground and polished.
- Outer ring:** Bronze, outer diameter ground. Sliding face made of high-duty bronze. Lubricant is distributed via the lubricating groove in the outer ring.
- Lubrication:** The lubricant enters the lubricating groove through a cross hole in the outer ring.
- Special versions:** - **Version -R:** as standard, but inner ring made of 100 Cr6 hard chromium plated at sliding surface.
 Further versions are available on request.

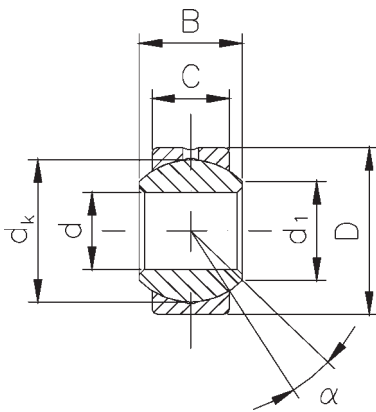

Designation	d	d ₁	B	C	D	dk	Load rating static C ₀	Tilt angle	Weight
	mm	mm	mm	mm	mm	mm	kN	α°	kg
G 5-NR	5	7.7	8	6.00	13	11.1	15	13	0.007
G 6-NR	6	8.9	9	6.75	16	12.7	19	13	0.010
G 8-NR	8	10.3	12	9.00	19	15.8	31	13	0.016
G 10-NR	10	12.9	14	10.50	22	19.0	43	13	0.031
G 12-NR	12	15.4	16	12.00	26	22.2	58	13	0.065
G 14-NR	14	16.8	19	13.50	28	25.4	74	15	0.090
G 16-NR	16	19.3	21	15.00	32	28.5	92	15	0.100
G 18-NR	18	21.8	23	16.50	35	31.7	112	15	0.125
G 20-NR	20	24.3	25	18.00	40	34.9	135	15	0.180
G 22-NR	22	25.8	28	20.00	42	38.1	164	15	0.210
G 25-NR	25	29.5	31	22.00	47	42.8	203	15	0.295
G 30-NR	30	34.8	37	25.00	55	50.8	273	15	0.425

Mating materials:
Stainless steel on
heavy-duty bronze
Maintenance required

Stainless steel
Special version type S

- Inner ring:** Stainless steel, hardened, ground and polished.
- Outer ring:** Bronze, outer diameter ground. Sliding face made of high-duty bronze. Lubricant is distributed via the lubricating groove in the outer ring.
- Outer case:** Stainless steel, outer diameter ground. Spherical bearing is pressed into the outer case and secured at both sides against axial movement.
- Lubrication:** The lubricant enters the lubricating groove through a cross hole in the outer case.
- Special versions:** - **Version -R:**
as standard, but inner ring made of 100 Cr6 hard chromium plated at sliding surface.
Further versions are available on request.

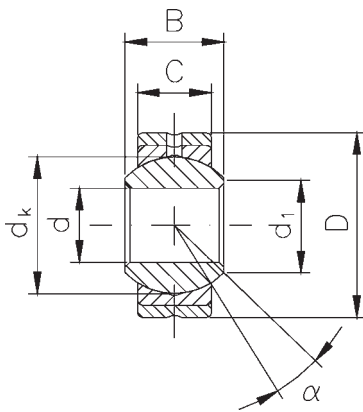

Designation	d	d ₁	B	C	D	dk	Load rating static C ₀	Tilt angle	Weight
	mm	mm	mm	mm	mm	mm	kN	α°	kg
S 6-NR	6	8.9	9	6.75	18	12.7	19	13	0.013
S 8-NR	8	10.3	12	9.00	22	15.8	31	13	0.024
S 10-NR	10	12.9	14	10.50	26	19.0	43	13	0.040
S 12-NR	12	15.4	16	12.00	30	22.2	58	13	0.080
S 14-NR	14	16.8	19	13.50	34	25.4	74	15	0.110
S 16-NR	16	19.3	21	15.00	38	28.5	92	15	0.130
S 18-NR	18	21.8	23	16.50	42	31.7	131	15	0.170
S 20-NR	20	24.3	25	18.00	46	34.9	157	15	0.230
S 22-NR	22	25.8	28	20.00	50	38.1	164	15	0.280
S 25-NR	25	29.5	31	22.00	56	42.8	203	15	0.390
S 30-NR	30	34.8	37	25.00	66	50.8	273	15	0.610

Mating materials:
Stainless steel on PTFE
Maintenance-free

Stainless steel
 Type G
 DIN ISO 12240-1
 dimension series K

Inner ring: Stainless steel, hardened, ground and polished.

Outer ring: Brass lined with an antifriction film, consisting of PTFE, outer diameter ground.

Special versions: - **Version -DR:**
 as standard, but inner ring made of 100 Cr6 hard chromium plated at sliding surface.

Further versions are available on request.

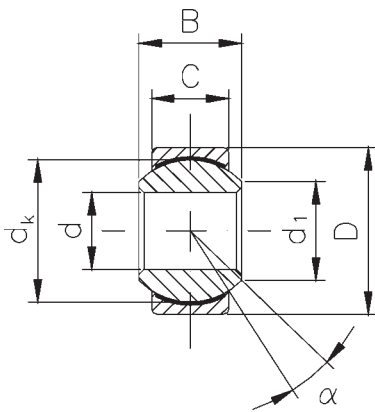

Designation	d	d ₁	B	C	D	dk	Load rating static C ₀	Tilt angle	Weight
	mm	mm	mm	mm	mm	mm	kN	α°	kg
G 5-DNR	5	7.7	8	6.00	13	11.1	14	13	0.007
G 6-DNR	6	8.9	9	6.75	16	12.7	18	13	0.010
G 8-DNR	8	10.3	12	9.00	19	15.8	30	13	0.016
G 10-DNR	10	12.9	14	10.50	22	19.0	42	13	0.031
G 12-DNR	12	15.4	16	12.00	26	22.2	56	13	0.065
G 14-DNR	14	16.8	19	13.50	28	25.4	72	15	0.090
G 16-DNR	16	19.3	21	15.00	32	28.5	90	15	0.100
G 18-DNR	18	21.8	23	16.50	35	31.7	110	15	0.125
G 20-DNR	20	24.3	25	18.00	40	34.9	132	15	0.180
G 22-DNR	22	25.8	28	20.00	42	38.1	160	15	0.210
G 25-DNR	25	29.5	31	22.00	47	42.8	198	15	0.295
G 30-DNR	30	34.8	37	25.00	55	50.8	267	15	0.425

Mating materials:
Stainless steel on PTFE
Maintenance-free

Stainless steel
Special version type S

- Inner ring:** Stainless steel, hardened, ground and polished.
- Outer ring:** Brass lined with an antifriction film, consisting of PTFE, cold formed around inner ring, outside diameter ground.
- Outer case:** Stainless steel, outer diameter ground. Spherical bearing is pressed into the outer case and secured at both sides against axial movement.
- Special versions:** - **Version -DR:** as standard, but inner ring made of 100 Cr6 hard chromium plated at sliding surface.
 Further versions are available on request.

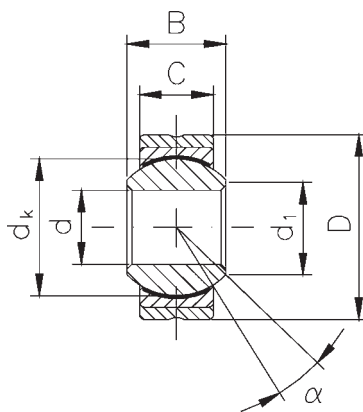

Designation	d	d ₁	B	C	D	d _k	Load rating static C ₀	Tilt angle	Weight
	mm	mm	mm	mm	mm	mm	kN	°	kg
S 6-DNR	6	8.9	9	6.75	18	12.7	18	13	0.013
S 8-DNR	8	10.3	12	9.00	22	15.8	30	13	0.024
S 10-DNR	10	12.9	14	10.50	26	19.0	42	13	0.040
S 12-DNR	12	15.4	16	12.00	30	22.2	56	13	0.080
S 14-DNR	14	16.8	19	13.50	34	25.4	72	15	0.110
S 16-DNR	16	19.3	21	15.00	38	28.5	90	15	0.130
S 18-DNR	18	21.8	23	16.50	42	31.7	110	15	0.170
S 20-DNR	20	24.3	25	18.00	46	34.9	132	15	0.230
S 22-DNR	22	25.8	28	20.00	50	38.1	160	15	0.280
S 25-DNR	25	29.5	31	22.00	56	42.8	198	15	0.390
S 30-DNR	30	34.8	37	25.00	66	50.8	267	15	0.610

Mating materials:
Stainless steel on PTFE
Maintenance-free

Stainless steel
copper alloys free
 Type G
 DIN ISO 12240-1
 dimension series K

Inner ring: Stainless steel, hardened, ground and polished.
Outer ring: Stainless steel lined with an antifriction film, consisting of PTFE, outer diameter ground.
Special versions: are available on request.

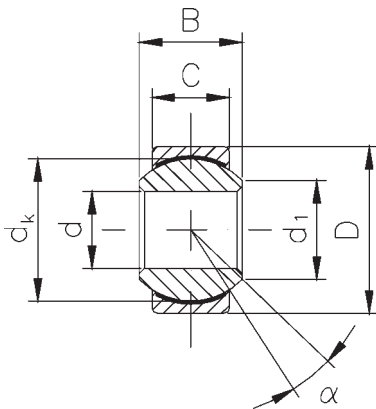

Designation	d	d ₁	B	C	D	dk	Load rating static C ₀	Tilt angle	Weight
	mm	mm	mm	mm	mm	mm	kN	α°	kg
G 6-DNRBF	6	8.9	9	6.75	16	12.7	18	13	0.010
G 8-DNRBF	8	10.3	12	9.00	19	15.8	30	13	0.016
G 10-DNRBF	10	12.9	14	10.50	22	19.0	42	13	0.031
G 12-DNRBF	12	15.4	16	12.00	26	22.2	56	13	0.065
G 14-DNRBF	14	16.8	19	13.50	28	25.4	72	15	0.090
G 16-DNRBF	16	19.3	21	15.00	32	28.5	90	15	0.100
G 18-DNRBF	18	21.8	23	16.50	35	31.7	110	15	0.125
G 20-DNRBF	20	24.3	25	18.00	40	34.9	132	15	0.180
G 22-DNRBF	22	25.8	28	20.00	42	38.1	160	15	0.210
G 25-DNRBF	25	29.5	31	22.00	47	42.8	198	15	0.295
G 30-DNRBF	30	34.8	37	25.00	55	50.8	267	15	0.425

Mating materials:
Stainless steel on PTFE
Maintenance-free

Stainless steel
copper alloys free
Special version type S

Inner ring: Stainless steel, hardened, ground and polished.

Outer ring: Stainless steel lined with an antifriction film, consisting of PTFE, outer diameter ground.

Outer case: Stainless steel, outer diameter ground. Spherical bearing is pressed into the outer case and secured at both sides against axial movement.

Special versions: are available on request.

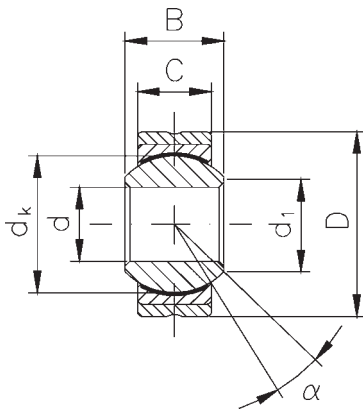

Designation	d	d ₁	B	C	D	dk	Load rating static C ₀	Tilt angle	Weight
	mm	mm	mm	mm	mm	mm	kN	°	kg
S 6-DNRBF	6	8.9	9	6.75	18	12.7	18	13	0.013
S 8-DNRBF	8	10.3	12	9.00	22	15.8	30	13	0.024
S 10-DNRBF	10	12.9	14	10.50	26	19.0	42	13	0.040
S 12-DNRBF	12	15.4	16	12.00	30	22.2	56	13	0.080
S 14-DNRBF	14	16.8	19	13.50	34	25.4	72	15	0.110
S 16-DNRBF	16	19.3	21	15.00	38	28.5	90	15	0.130
S 18-DNRBF	18	21.8	23	16.50	42	31.7	110	15	0.170
S 20-DNRBF	20	24.3	25	18.00	46	34.9	132	15	0.230
S 22-DNRBF	22	25.8	28	20.00	50	38.1	160	15	0.280
S 25-DNRBF	25	29.5	31	22.00	56	42.8	198	15	0.390
S 30-DNRBF	30	34.8	37	25.00	66	50.8	267	15	0.610

Mating materials:
Steel on steel
Maintenance required

RS
Special version
2RS sealing

- Inner ring:** Antifriction bearing steel, hardened, ground and polished.
- Outer ring:** Made of heat-treated steel. Lubricant is distributed via the lubrication groove in the outer ring.
- Rubber bellows:** Synthetic rubber.
- Lubrication:** The lubricant enters the lubricating groove through a cross hole in the outer ring.
- Tolerances:** To DIN ISO 12240-1, schedule K, except: $d = H8$, $B = \pm 0.3$
- Note:** With these rod ends, it is important to ensure that the tilt angle specified in the table is not exceeded, either while mounting or during operation, otherwise the rubber bellows may be damaged. Replacement for previous 2RS-version. Available on request.
- Special versions:**
 - Mating materials steel on high-duty bronze
 - Mating materials steel on steel with anti-friction coating

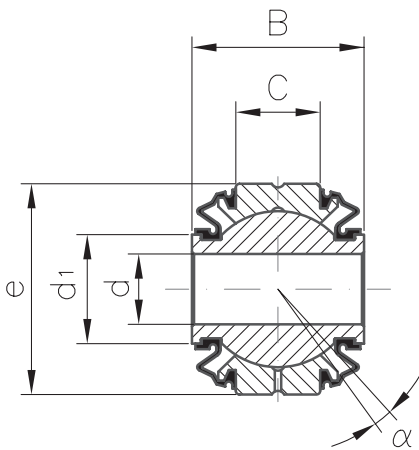

Designation	d	d ₁	B	C	e	Load rating static C ₀	Tilt angle	Weight
	mm	mm	mm	mm	mm	kN	α°	kg
S 8-RS	6	11.0	19	9.0	22	31	9	0.035
S 10-RS	8	13.0	21	10.5	26	43	9	0.065
S 12-RS	10	15.5	23	12.0	30	58	9	0.110
S 14-RS	12	17.0	26	13.5	34	74	10	0.150
S 16-RS	14	19.5	28	15.0	38	92	10	0.180
S 18-RS	16	22.5	30	16.5	42	112	10	0.225
S 20-RS	18	24.5	32	18.0	46	135	10	0.300
S 22-RS	20	26.5	35	20.0	50	164	10	0.350
S 25-RS	22	29.5	38	22.0	56	236	10	0.470
S 30-RS	25	35.0	44	25.0	66	273	12	0.690

Mating materials:
Steel on PFFE
Maintenance-free

RS
Special version
RS sealing

Inner ring: Antifriction bearing steel, hardened, ground and polished.

Outer ring: Steel lined with an antifriction film, consisting PTFE.

Rubber bellows: Synthetic rubber.

Tolerances: Acc. To DIN ISO 12240-1, schedule K, except: $d = H8$, $B = +0.3$

Note: With these rod ends, it is important to ensure that the tilt angle specified in the table is not exceeded, either while mounting or during operation, otherwise the rubber bellows may be damaged. Replacement for previous 2RS-version. Available on request.

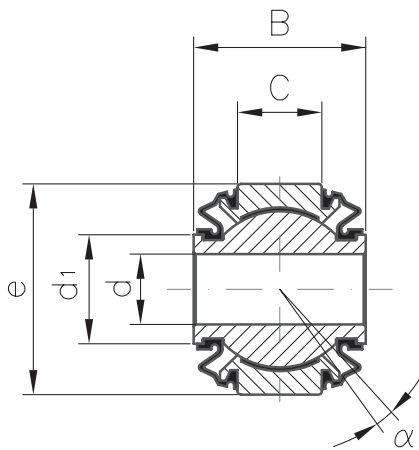

Designation	d	d ₁	B	C	e	Load rating static C ₀	Tilt angle	Weight
Righthand thread	mm	≈ mm	mm	mm	mm	kN	α°	kg
S 8-DRS	6	11.5	19	9.0	22	30	9	0.035
S 10-DRS	8	13.5	21	10.5	26	42	9	0.065
S 12-DRS	10	15.5	23	12.0	30	56	9	0.110
S 14-DRS	12	17.5	26	13.5	34	72	10	0.150
S 16-DRS	14	19.5	28	15.0	38	90	10	0.180
S 18-DRS	16	22.5	30	16.5	42	110	10	0.225
S 20-DRS	18	24.5	32	18.0	46	132	10	0.300
S 22-DRS	20	26.5	35	20.0	50	160	10	0.350
S 25-DRS	22	29.5	38	22.0	56	198	10	0.470
S 30-DRS	25	35.0	44	25.0	66	267	12	0.690



Mating materials:
Steel on high-duty bronze
Maintenance required

2RS version
Special version
2RS sealing

- Inner ring:** Antifriction bearing steel, hardened, ground and polished.
- Bearing shells:** Sliding face made of high-duty bronze. Both shells have a male thread and are screwed into the housing. In this way, any required bearing clearance can be adjusted and then secured with the two vulcanised locknuts of the rubber bellows.
- Rubber bellows:** Synthetic rubber with vulcanised brass slipping and steel locknut
- Bushings:** Tempering steel, hardened, bore and outside diameter ground, pressed into the inner ring. They are only used as intake of the brass abrasive rings of the rubber bellows. Due to their low thickness they are not dedicated to transmit radial and axial forces into the spherical bearing.
- Lubricating:** The lubricant enters the lubricating groove through a cross hole in the outer ring
- Tolerances:** To DIN ISO 12240-4, schedule K, except: $d = H10$, $B = \pm 0,3$
- Note:** With these rod ends, it is important to ensure that the tilt angle specified in the table is not exceeded, either while mounting or during operation, otherwise the rubber bellows may be damaged.

Standard

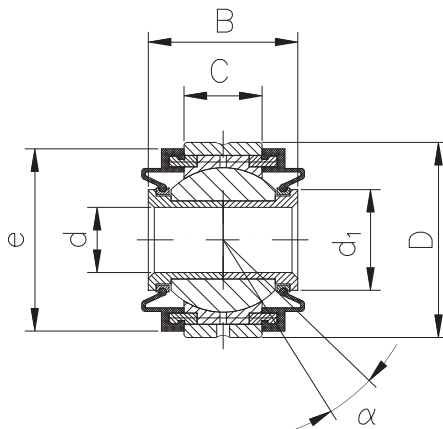

Designation	d	d ₁	B	C	D	e	Load ratings stat C ₀ kN	Tilt angle α°	Weight kg
	mm	≈				≈			
S 8-STK2RS	6	10,5	19	9,0	22	20	31	9	0,035
S 10-STK2RS	8	13,0	21	10,5	26	24	43	9	0,065
S 12-STK2RS	10	15,5	23	12,0	30	28	58	9	0,110
S 14-STK2RS	12	17,0	26	13,5	34	30	74	10	0,150
S 16-STK2RS	14	19,5	28	15,0	38	34	92	10	0,180
S 18-STK2RS	16	22,5	30	16,5	42	37	112	10	0,225
S 20-STK2RS	18	24,5	32	18,0	46	40	135	10	0,300
S 22-STK2RS	20	26,0	35	20,0	50	44	164	10	0,350
S 25-STK2RS	22	29,5	38	22,0	56	50	236	10	0,470
S 30-STK2RS	25	35,0	44	25,0	66	58	273	12	0,690

Mating materials:
Steel on PTFE
Maintenance-free

2RS version
Special version
2RS sealing

- Inner ring:** Antifriction bearing steel, hardened, ground and polished.
- Outer ring:** Brass lined with an antifriction film, consisting PTFE, cold formed around inner ring, outside diameter with thread, screwed into housing and secured with the vulcanised brass slipping and steel locknut.
- Rubber bellows:** Synthetic rubber with vulcanised brass slipping and steel locknut
- Bushings:** Tempering steel, hardened, bore and outside diameter ground, pressed into the inner ring. They are only used as intake of the brass abrasive rings of the rubber bellows. Due to their low thickness they are not dedicated to transmit radial and axial forces into the spherical bearing.
- Tolerances:** Acc. to DIN ISO 12240-4, schedule K, except: $d = H10$, $B = \pm 0,3$
- Note:** With these rod ends, it is important to ensure that the tilt angle specified in the table is not exceeded, either while mounting or during operation, otherwise the rubber bellows may be damaged.

Standard

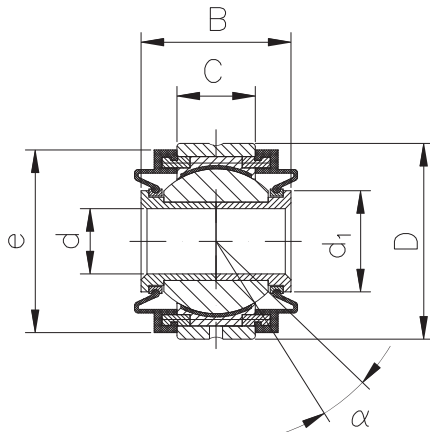

Designation	d	d ₁	B	C	D	e	Load ratings stat C ₀ kN	Tilt angle α°	Weight kg
	mm	≈				≈			
S 8-D2RS	6	10,5	19	9,0	22	20	30	9	0,035
S 10-D2RS	8	13,0	21	10,5	26	24	42	9	0,065
S 12-D2RS	10	15,5	23	12,0	30	28	56	9	0,110
S 14-D2RS	12	17,0	26	13,5	34	30	72	10	0,150
S 16-D2RS	14	19,5	28	15,0	38	34	90	10	0,180
S 18-D2RS	16	22,5	30	16,5	42	37	110	10	0,225
S 20-D2RS	18	24,5	32	18,0	46	40	132	10	0,300
S 22-D2RS	20	26,0	35	20,0	50	44	160	10	0,350
S 25-D2RS	22	29,5	38	22,0	56	50	198	10	0,470
S 30-D2RS	25	35,0	44	25,0	66	58	267	12	0,690

Mating materials:
Steel on steel
Maintenance required

DO
 DIN ISO 12240-1
 dimension series E

Inner ring: Antifriction bearing steel, hardened, ground.

Outer ring: Antifriction bearing steel, hardened, ground. Outer ring is split for assembly of inner ring.

Lubrication: Sizes 6 to 15 without lubrication groove and lubrication hole. Form size 17 upwards, relubrication is also possible through the inner bore.

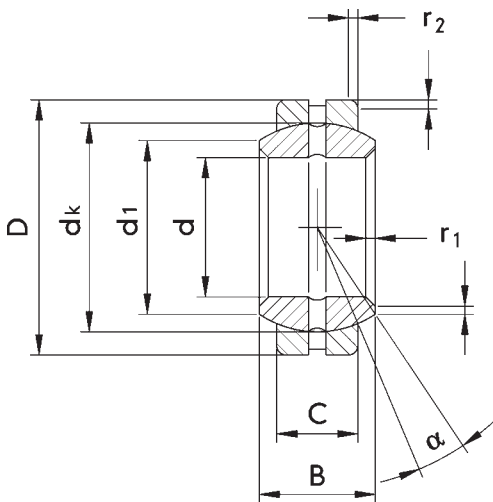

Designation	d	d ₁	B	C	D	dk	r ₁	r ₂	Load rating static C ₀	Tilt angle	Weight
	mm	≈ mm	mm	mm	mm	mm	min. mm	min. mm	kN	≈ α°	kg
GE 6-DO	6	8	6	4	14	10	0.3	0.3	17	13	0.004
GE 8-DO	8	10	8	5	16	13	0.3	0.3	27	15	0.008
GE 10-DO	10	13	9	6	19	16	0.3	0.3	40	12	0.011
GE 12-DO	12	15	10	7	22	18	0.3	0.3	53	10	0.015
GE 15-DO	15	18	12	9	26	22	0.3	0.3	84	8	0.027
GE 17-DO	17	20	14	10	30	25	0.3	0.3	106	10	0.041
GE 20-DO	20	24	16	12	35	29	0.3	0.3	146	9	0.066
GE 25-DO	25	29	20	16	42	35	0.6	0.6	240	7	0.119
GE 30-DO	30	34	22	18	47	40	0.6	0.6	310	6	0.153
GE 35-DO	35	39	25	20	55	47	0.6	1.0	399	6	0.233
GE 40-DO	40	45	28	22	62	53	0.6	1.0	495	7	0.306
GE 45-DO	45	50	32	25	68	60	0.6	1.0	637	7	0.427
GE 50-DO	50	55	35	28	75	66	0.6	1.0	780	6	0.939
GE 60-DO	60	66	44	36	90	80	1.0	1.0	1220	6	1.040
GE 70-DO	70	77	49	40	105	92	1.0	1.0	1560	6	1.550
GE 80-DO	80	88	55	45	120	105	1.0	1.0	2000	6	2.310
GE 90-DO	90	98	60	50	130	115	1.0	1.0	2440	5	2.750
GE 100-DO	100	109	70	55	150	130	1.0	1.0	3030	7	4.450
GE 110-DO	110	120	70	55	160	140	1.0	1.0	3270	6	4.820
GE 120-DO	120	130	85	70	180	160	1.0	1.0	4750	6	8.050
GE 140-DO	140	150	90	70	210	180	1.0	1.0	5350	7	11.020
GE 160-DO	160	170	105	80	230	200	1.0	1.0	6800	8	14.010
GE 180-DO	180	192	105	80	260	225	1.1	1.1	7650	6	18.650
GE 200-DO	200	212	130	100	290	250	1.1	1.1	10600	7	28.030

Mating materials:
Steel on steel
Maintenance required

FO
DIN ISO 12240-1
dimension series G

- Inner ring:** Antifriction bearing steel, hardened, ground.
- Outer ring:** Antifriction bearing steel, hardened, ground. Outer ring is split for assembly of inner ring.
- Lubrication:** Lubrication groove and lubrication hole, relubrication is also possible through the inner bore.

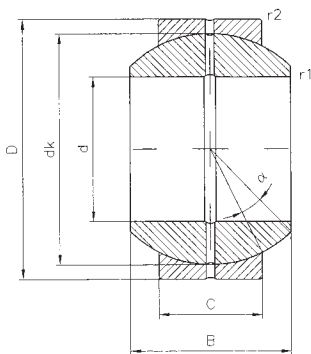

Designation	d	B	C	D	dk	r ₁	r ₂	Load rating static C ₀	Tilt angle	Weight
	mm	mm	mm	mm	mm	mm	mm	kN	α°	kg
GE 20-FO	20	25	16	42	35.5	0.6	0.6	240	17	0.15
GE 25-FO	25	28	18	47	40.7	0.6	0.6	310	17	0.19
GE 30-FO	30	32	20	55	47.0	0.6	1.0	400	17	0.29
GE 35-FO	35	35	23	62	53.0	0.6	1.0	500	16	0.39
GE 40-FO	40	40	25	68	60.0	0.6	1.0	640	17	0.52
GE 45-FO	45	43	28	75	66.0	0.6	1.0	780	15	0.68
GE 50-FO	50	56	36	90	80.0	0.6	1.0	1120	17	1.40
GE 60-FO	60	63	40	105	92.0	1.0	1.0	1560	17	2.00
GE 70-FO	70	70	45	120	105.0	1.0	1.0	2000	16	2.90
GE 80-FO	80	75	50	130	115.0	1.0	1.0	2450	14	3.50
GE 90-FO	90	85	55	150	130.0	1.0	1.0	3050	15	5.40
GE 100-FO	100	85	55	160	140.0	1.0	1.0	3250	14	5.90

Mating materials:
Steel on steel
Maintenance required

LO
 DIN ISO 12240-1
 dimension series W

Inner ring: Antifriction bearing steel, hardened, ground.

Outer ring: Antifriction bearing steel, hardened, ground. Outer ring is split for assembly of inner ring.

Lubrication: Lubrication groove and lubrication hole, relubrication is also possible through the inner bore.

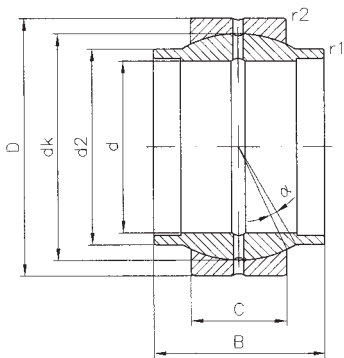

Designation	d	d ₂ min. mm	B	C	D	dk	r ₁	r ₂	Load rating static C ₀ kN	Tilt angle α°	Weight kg
GE 20-LO	20	25.0	20	12	35.0	29.0	0.3	0.3	146	4	0.070
GE 25-LO	25	30.0	25	16	42.0	35.5	0.6	0.6	240	4	0.120
GE 32-LO	32	38.0	32	18	52.0	44.0	0.6	1.0	335	4	0.200
GE 40-LO	40	46.0	40	22	62.0	53.0	0.6	1.0	500	4	0.340
GE 50-LO	50	57.0	50	28	75.0	66.0	0.6	1.0	780	4	0.560
GE 63-LO	63	71.5	63	36	95.0	83.0	0.1	1.0	1270	4	1.200
GE 70-LO	70	79.0	70	40	105.0	92.0	1.0	1.0	1560	4	1.700
GE 80-LO	80	91.0	80	45	120.0	105.0	1.0	1.0	2000	4	2.400

Mating materials:
Steel on PTFE
Maintenance-free

UK
DIN ISO 12240-1
dimension series E

Inner ring: Antifriction bearing steel, hardened, ground and polished.
Outer ring: Steel, lined with PTFE.
Sealing: Sealing rings at both sides.

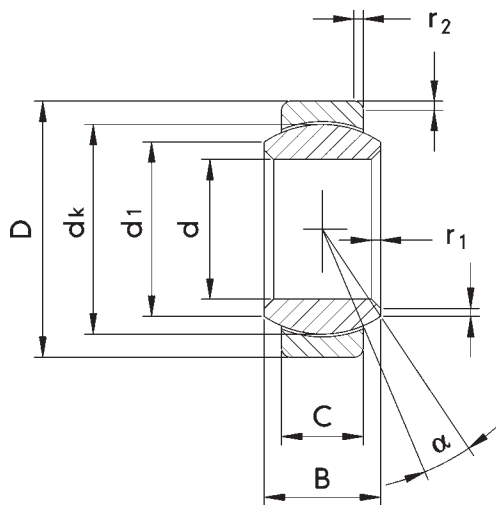

Designation	d	d ₁	B	C	D	dk	r ₁	r ₂	Load rating static C ₀	Tilt angle	Weight
	mm	≈ mm	mm	mm	mm	mm	min. mm	min. mm	kN	≈ α°	kg
GE 6-UK	6	8	6	4	14	10	0.3	0.3	9	13	0.004
GE 8-UK	8	10	8	5	16	13	0.3	0.3	14	15	0.008
GE 10-UK	10	13	9	6	19	16	0.3	0.3	21	12	0.011
GE 12-UK	12	15	10	7	22	18	0.3	0.3	28	10	0.015
GE 15-UK	15	18	12	9	26	22	0.3	0.3	45	8	0.027
GE 17-UK	17	20	14	10	30	25	0.3	0.3	56	10	0.041
GE 17-UK2RS	17	20	14	10	30	25	0.3	0.3	60	10	0.041
GE 20-UK	20	24	16	12	35	29	0.3	0.3	78	9	0.066
GE 20-UK2RS	20	24	16	12	35	29	0.3	0.3	83	9	0.066
GE 25-UK	25	29	20	16	42	35	0.6	0.6	127	7	0.119
GE 25-UK2RS	25	29	20	16	42	35	0.6	0.6	137	7	0.119
GE 30-UK	30	34	22	18	47	40	0.6	0.6	166	6	0.153
GE 30-UK2RS	30	34	22	18	47	40	0.6	0.6	176	6	0.153
GE 35-UK2RS	35	39	25	20	55	47	0.6	1.0	224	6	0.233
GE 40-UK2RS	40	45	28	22	62	53	0.6	1.0	280	7	0.306
GE 45-UK2RS	45	50	32	25	68	60	0.6	1.0	360	7	0.427
GE 50-UK2RS	50	55	35	28	75	66	0.6	1.0	440	6	0.939
GE 60-UK2RS	60	66	44	36	90	80	1.0	1.0	695	6	1.040
GE 70-UK2RS	70	77	49	40	105	92	1.0	1.0	880	6	1.550
GE 80-UK2RS	80	88	55	45	120	105	1.0	1.0	1140	6	2.310
GE 90-UK2RS	90	98	60	50	130	115	1.0	1.0	1370	5	2.750
GE 100-UK2RS	100	109	70	55	150	130	1.0	1.0	1730	7	4.450
GE 110-UK2RS	110	120	70	55	160	140	1.0	1.0	1860	6	4.820
GE 120-UK2RS	120	130	85	70	180	160	1.0	1.0	2700	6	8.050

Mating materials:
Steel on PTFE
Maintenance-free

TGR
DIN ISO 12240-1
dimension series E

Inner ring: Stainless steel, hardened, ground and polished.
Outer ring: Stainless steel lined with PTFE, cold formed around the inner ring.

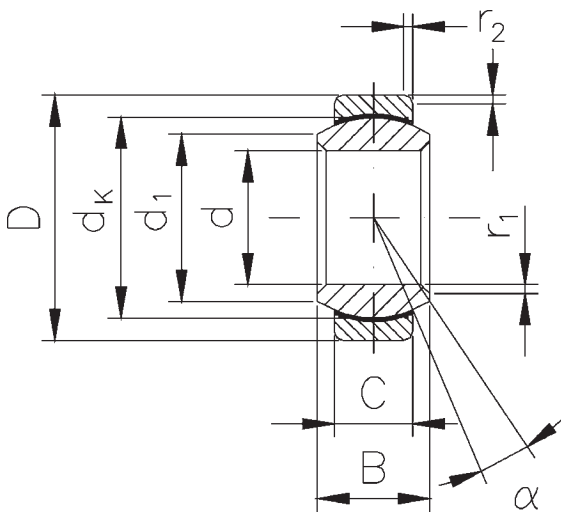

Designation	d	d ₁	B	C	D	dk	r ₁	r ₂	Load rating static C ₀	Tilt angle	Weight
	mm	mm	mm	mm	mm	mm	mm	mm	kN	α°	kg
GE 8-TGR	8	10	8	5	16	13.0	0.5	0.5	15	15	0.008
GE 10-TGR	10	13	9	6	19	16.0	0.8	0.5	22	12	0.012
GE 12-TGR	12	15	10	7	22	18.0	0.8	0.8	29	11	0.017
GE 15-TGR	15	18	12	9	26	22.0	0.8	0.8	44	9	0.032
GE 17-TGR	17	20	14	10	30	25.0	0.8	0.8	56	10	0.049
GE 20-TGR	20	24	16	12	35	29.0	0.8	1.0	78	9	0.065
GE 25-TGR	25	29	20	16	42	35.5	0.8	1.0	127	8	0.115
GE 30-TGR	30	34	22	18	47	40.7	0.8	1.0	166	7	0.160

Mating materials:
Steel on steel
Maintenance required

DO2RS
DIN ISO 12240-1
dimension series E
2RS sealing

- Inner ring:** Antifriction bearing steel, hardened, ground.
- Outer ring:** Antifriction bearing steel, hardened, ground. Outer ring is split for assembly of inner ring.
- Sealing:** Sealing rings at both sides.
- Lubrication:** Sizes 6 to 15 without lubrication groove and lubrication hole. Form size 17 upwards, relubrication is also possible through the inner bore.

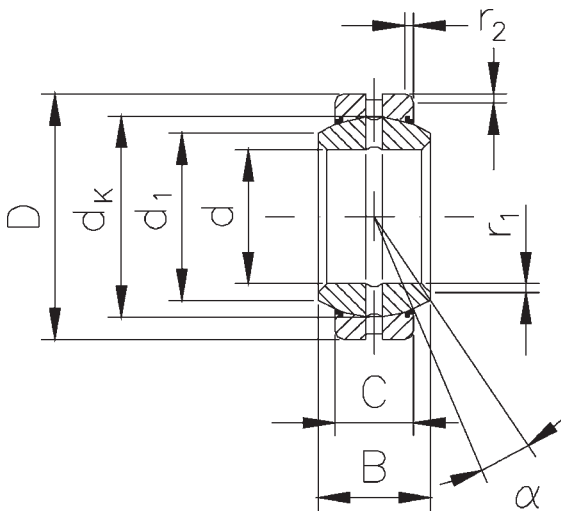

Designation	d	d ₁	B	C	D	dk	r ₁	r ₂	Load rating static C ₀	Tilt angle	Weight
	mm	mm	mm	mm	mm	mm	mm	mm	kN	α°	kg
GE 15-DO2RS	15	18	12	9	26	22.0	0.8	0.8	84	9	0.032
GE 17-DO2RS	17	20	14	10	30	25.0	0.8	0.8	106	10	0.049
GE 20-DO2RS	20	24	16	12	35	29.0	0.8	1.0	146	9	0.065
GE 25-DO2RS	25	29	20	16	42	35.5	0.8	1.0	240	8	0.115
GE 30-DO2RS	30	34	22	18	47	40.7	0.8	1.0	310	7	0.160
GE 35-DO2RS	35	39	25	20	55	47.0	1.0	1.2	399	7	0.258
GE 40-DO2RS	40	45	28	22	62	53.0	1.0	1.2	495	7	0.315
GE 45-DO2RS	45	50	32	25	68	60.0	1.0	1.2	637	8	0.413
GE 50-DO2RS	50	56	35	28	75	66.0	1.0	1.2	780	7	0.560
GE 60-DO2RS	60	66	44	36	90	80.0	1.2	1.5	1220	7	1.100
GE 70-DO2RS	70	77	49	40	105	92.0	1.2	1.5	1560	6	1.540
GE 80-DO2RS	80	89	55	45	120	105.0	1.2	1.5	2000	6	2.290

Mating materials:
Steel on steel
Maintenance required

FO2RS
 DIN ISO 12240-1
 dimension series G
 2RS-sealing

Inner ring: Antifriction bearing steel, hardened, ground.

Outer ring: Antifriction bearing steel, hardened, ground. Outer ring is split for assembly of inner ring.

Lubrication: Lubrication groove and lubrication hole, relubrication is also possible through the inner bore.

Sealing: Sealing rings at both sides.

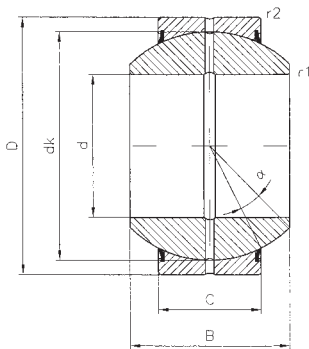

Designation	d	B	C	D	dk	r ₁	r ₂	Load rating static C ₀	Tilt angle	Weight
	mm	mm	mm	mm	mm	mm	mm	kN	α°	kg
GE 20-FO2RS	20	25	16	42	35.5	0.6	0.6	240	17	0.15
GE 25-FO2RS	25	28	18	47	40.7	0.6	0.6	310	17	0.19
GE 30-FO2RS	30	32	20	55	47.0	0.6	1.0	400	17	0.29
GE 35-FO2RS	35	35	23	62	53.0	0.6	1.0	500	16	0.39
GE 40-FO2RS	40	40	25	68	60.0	0.6	1.0	640	17	0.52
GE 45-FO2RS	45	43	28	75	66.0	0.6	1.0	780	15	0.68
GE 50-FO2RS	50	56	36	90	80.0	0.6	1.0	1120	17	1.40
GE 60-FO2RS	60	63	40	105	92.0	1.0	1.0	1560	17	2.00
GE 70-FO2RS	70	70	45	120	105.0	1.0	1.0	2000	16	2.90
GE 80-FO2RS	80	75	50	130	115.0	1.0	1.0	2450	14	3.50
GE 90-FO2RS	90	85	55	150	130.0	1.0	1.0	3050	15	5.40
GE 100-FO2RS	100	85	55	160	140.0	1.0	1.0	3250	14	5.90

Mating materials:
Steel on steel
Maintenance required

HO2RS
2RS-sealing

- Inner ring:** Antifriction bearing steel, hardened, ground.
Outer ring: Antifriction bearing steel, hardened, ground. Outer ring is split for assembly of inner ring.
Lubrication: Lubrication groove and lubrication hole, relubrication is also possible through the inner bore.
Radial clearance: see technical basics, table spherical bearings dimension series E, mating materials steel on steel.
Sealing: Sealing rings at both sides.

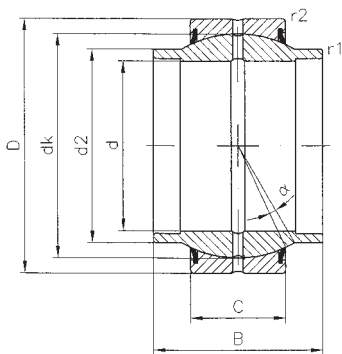

Designation	d	d ₂	B	C	D	dk	r ₁	r ₂	Load rating static C ₀	Tilt angle	Weight
	mm	min. mm	mm	mm	mm	mm	mm	mm	kN	°	kg
GE 20-HO2RS	20	24.0	24	12	35	29.0	0.2	0.3	146	3	0.057
GE 25-HO2RS	25	29.0	29	16	42	35.5	0.2	0.6	240	3	0.100
GE 30-HO2RS	30	34.2	30	18	47	40.7	0.2	0.6	310	3	0.140
GE 35-HO2RS	35	40.0	35	20	55	47.0	0.3	1.0	400	3	0.240
GE 40-HO2RS	40	45.0	38	22	62	53.0	0.3	1.0	500	3	0.290
GE 45-HO2RS	45	51.5	40	25	68	60.0	0.3	1.0	640	3	0.430
GE 50-HO2RS	50	56.5	43	28	75	66.0	0.3	1.0	780	3	0.540
GE 60-HO2RS	60	67.7	54	36	90	80.0	0.3	1.0	1220	3	1.100
GE 70-HO2RS	70	78.0	65	40	105	92.0	0.3	1.0	1560	3	1.600
GE 80-HO2RS	80	90.0	74	45	120	105.0	0.3	1.0	2000	3	2.400

